

Архангельск (8182)63-90-72
Астана (7172)727-132
Астрахань (8512)99-46-04
Барнаул (3852)73-04-60
Белгород (4722)40-23-64
Брянск (4832)59-03-52
Владивосток (423)249-28-31
Волгоград (844)278-03-48
Вологда (8172)26-41-59
Воронеж (473)204-51-73
Екатеринбург (343)384-55-89
Иваново (4932)77-34-06

Ижевск (3412)26-03-58
Иркутск (395)279-98-46
Казань (843)206-01-48
Калининград (4012)72-03-81
Калуга (4842)92-23-67
Кемерово (3842)65-04-62
Киров (8332)68-02-04
Краснодар (861)203-40-90
Красноярск (391)204-63-61
Курск (4712)77-13-04
Липецк (4742)52-20-81
Киргизия (996)312-96-26-47

Магнитогорск (3519)55-03-13
Москва (495)268-04-70
Мурманск (8152)59-64-93
Набережные Челны (8552)20-53-41
Нижегород (831)429-08-12
Новокузнецк (3843)20-46-81
Новосибирск (383)227-86-73
Омск (3812)21-46-40
Орел (4862)44-53-42
Оренбург (3532)37-68-04
Пенза (8412)22-31-16
Казахстан (772)734-952-31

Пермь (342)205-81-47
Ростов-на-Дону (863)308-18-15
Рязань (4912)46-61-64
Самара (846)206-03-16
Санкт-Петербург (812)309-46-40
Саратов (845)249-38-78
Севастополь (8692)22-31-93
Симферополь (3652)67-13-56
Смоленск (4812)29-41-54
Сочи (862)225-72-31
Ставрополь (8652)20-65-13

Сургут (3462)77-98-35
Тверь (4822)63-31-35
Томск (3822)98-41-53
Тула (4872)74-02-29
Тюмень (3452)66-21-18
Ульяновск (8422)24-23-59
Уфа (347)229-48-12
Хабаровск (4212)92-98-04
Челябинск (351)202-03-61
Череповец (8202)49-02-64
Ярославль (4852)69-52-93

<https://autop.nt-rt.ru> || aft@nt-rt.ru

КАТАЛОГ

накладные подъемники



VERTICAL
POWER

**Workshop equipment in
premium quality**

Surface-mounted lifts



More than 100 years of experience in lifting technology

Made in Germany & Made in Denmark

We develop and produce inground lifts in Germany and surface-mounted lifts in Denmark for an intensive and long-term use in your workshop.

AUTOPSTENHOJ's product quality is also appreciated by leading car manufacturers through approvals and recommendations.

We offer solutions and not only products!

The greatest challenge with modern vehicles has been and is still to reach the correct lifting points so that the vehicle can be lifted safely and without damage at its underbody. With our extensive range of lifting adaptors we have a solution for almost every vehicle.

Our premium solution is the distribution of our products through competent partners, ensuring the best possible support for our customers during the product's entire life cycle.

Our vision:

"AUTOPSTENHOJ offers the best total experience for the premium market of workshop solutions."

AUTOPSTENHOJ has been setting standards in the sector for many years. Not only our portfolio's wide range but also the quality of manufacturing and the design are unique.

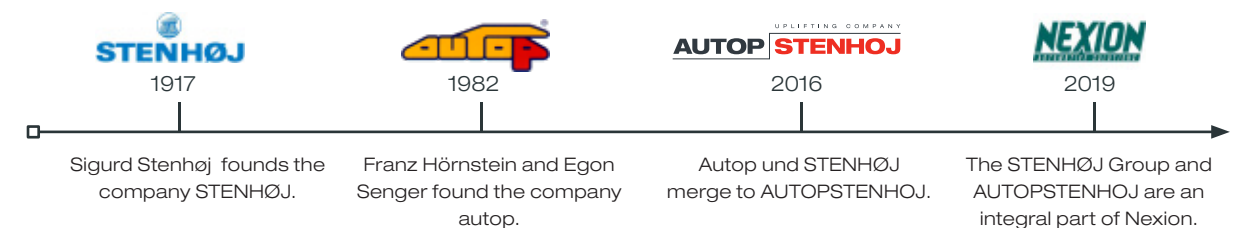

Welcome to AUTOPSTENHOJ.

AUTOPSTENHOJ - Workshop equipment in premium quality

We offer solutions and not only products!

AUTOPSTENHOJ is manufacturer and supplier of workshop equipment for the global automotive market and stands for innovative processes and top-quality products. Our goal: We want to be the market leader and for you the first choice for lifting and testing technology, workshop equipment and related services.

Due to our decades of experience and trustful cooperation with the leading car manufacturers we are able to offer a comprehensive range of approved inground and surface-mounted lifts. Planning, advice and assembly as well as technical support round off our various range of performances.

One strong brand for all markets!



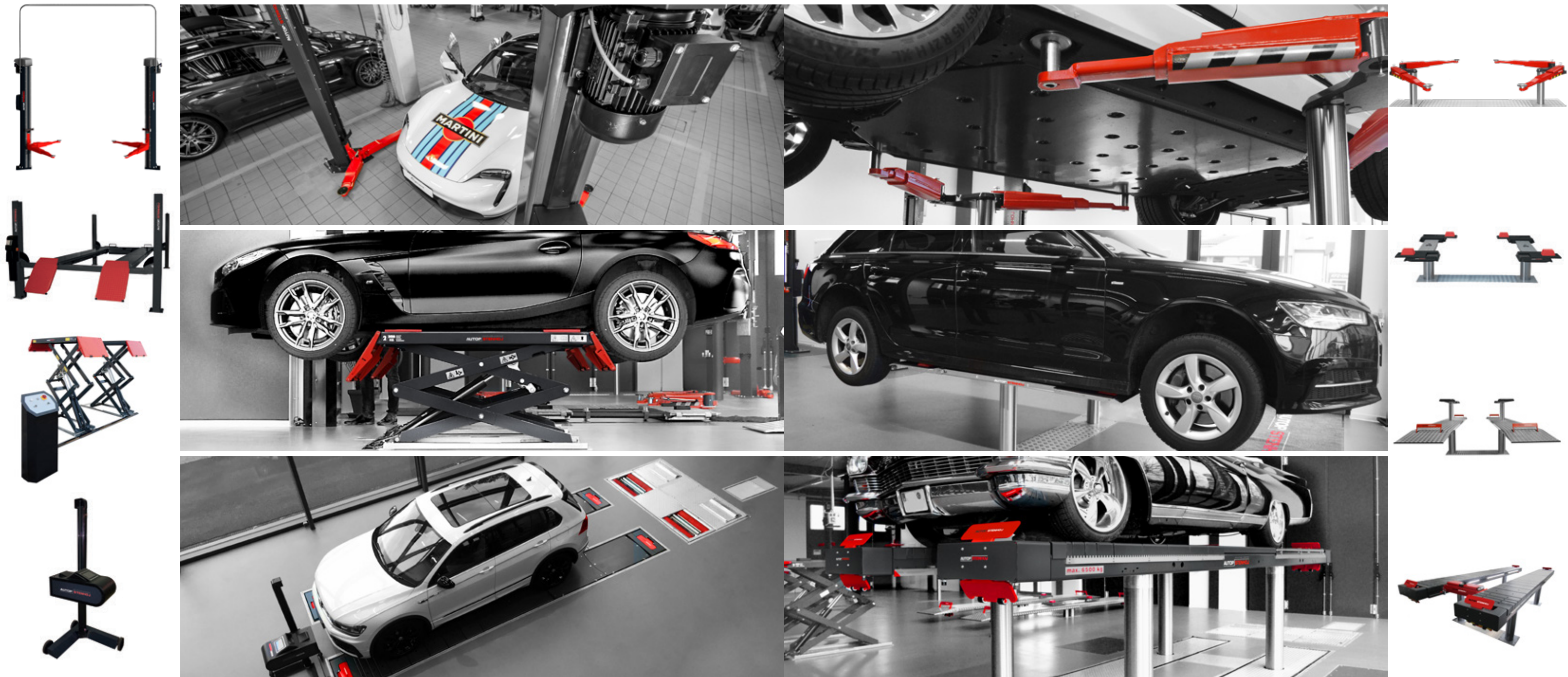

**Recommended by leading
car manufacturers.**

AUTOPSTENHOJ - Workshop equipment in premium quality

For decades we have been a recommended supplier for lifts to leading car manufacturers.
Of course, we deliver our products with all the required features according to manufacturer CI.

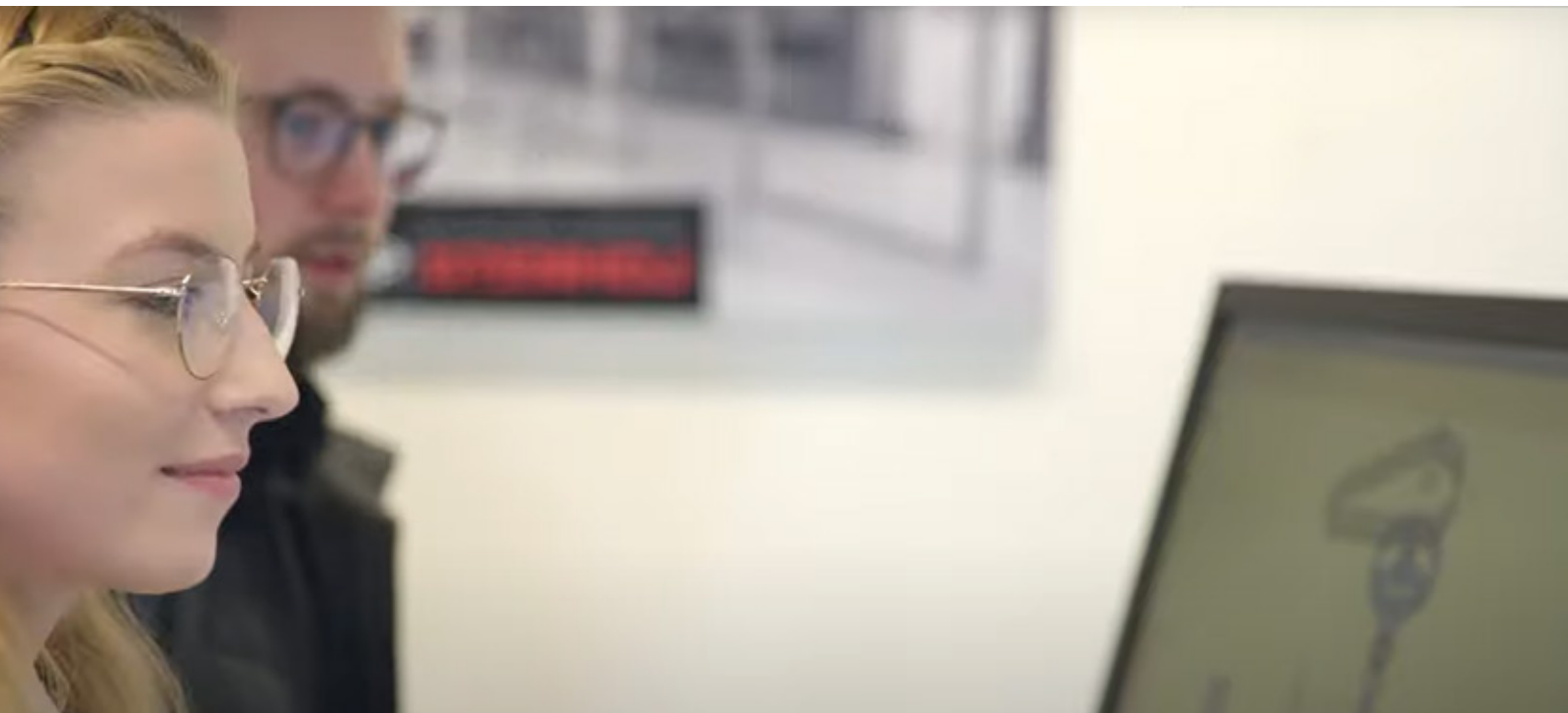

Thanks to over 100 years of experience within the sector, today we can fall back upon a maximum degree of know-how. The best basis for the future. For example with the designers and engineers of our own R&D department who are constantly working on the lifts of the future. We offer lifts from our standard portfolio that have been tested thousands of times and can safely lift also the most modern vehicles like e-cars or hydrogen-powered cars, thanks to our wide and constantly developed range of lifting pads and wheel support devices.

Every new generation of technology needs a new generation of people. To secure our innovative strength, we at AUTOPSTENHOJ consistently focus on the further training of our employees and the education of young people. Thus, many trainees prepare themselves regularly for tomorrow's challenges.

**Trust in our experience and
our innovative spirit.**





Know-how with Wow-effect: Our AUTOPSTENHOJ Academy.

AUTOPSTENHOJ Academy

Practical experience and training with workshop equipment

As manufacturer of premium products, we not only want to provide our customers with premium workshop equipment, but also make sure that they get the best support before and after the purchase.

In the AUTOPSTENHOJ Academy our customers can convince themselves personally of our products' quality and suitability: **Experience AUTOPSTENHOJ!**

If necessary, we arrange lifting tests with certain vehicle types so that no questions remain open.

Additionally, our sales partners get regularly trained in our Academy, ensuring the highest competence for our customers in the field of AUTOPSTENHOJ technology: on a high training level and every time state-of-the-art.

A spacious show room and two training rooms with a total space of 440 m² are available in the AUTOPSTENHOJ Academy.

AUTOPSTENHOJ seal for sales and service partners

The leading car manufacturers and more and more car dealership chains demand certifications from their suppliers; the European Union makes these recommendations, too. Therefore we decided to implement a seal which makes us together with our partners even more recognizable on the market.

The AUTOPSTENHOJ seal certifies the value of our partners' performances in sales and technology. A regular attendance at intensive trainings in the AUTOPSTENHOJ Academy is obligatory to get this seal. The trainings impart detailed technical knowledge about our products to our partners.

The certified partners are entitled to use the certificate and the AUTOPSTENHOJ seal for 2 years.

With this first-hand knowledge, our partners are always up to date and the service quality remains on the highest level.





Customer service with commitment, expertise and high customer orientation.

High customer orientation:

Our products are designed for a long lifetime of service. Therefore, a customer relationship does not end with the purchase of a lift, but it continues to grow. And that can be a very long customer relationship. Many of our lifts have been in operation for more than 40 years now. We still keep the relevant spare parts in stock and this is true for a number of very old lift types, too! We can be proud of the fact that more than 75,000 of our inground and several hundreds of thousands surface-mounted lifts are operating worldwide on a daily basis.

A professional lift installation.

The best lift in the world is useless if it is not installed correctly. AUTOPSTENHOJ has the experience, equipment and capabilities to provide complete installation service which can also include construction work. Our highly trained service team is committed to your goals with great dedication, expertise and a high level of customer orientation.

Constant training programs for service teams.

Over the decades our partner network has grown significantly and they all have their own sales and service organizations. These good partnerships are based on our responsibilities to organize continuous sales and service training. This direct knowledge transfer keeps our partners up-to-date and delivers a high quality service to customers around the world.





Customer satisfaction is our top priority.

Many workshops have been equipped all over the world, among these the Lamborghini dealership in Kuwait. Likewise, there are now 47 of our lifts installed in the BMW subsidiary in Brussels. All lifts supplied were manufactured according to the customer's special design and are suitable for the whole BMW range, including the electric cars i3 & i8. So does the Mercedes Benz branch in Berlin which we equipped with more than 60 AUTOPSTENHOJ lifts and nearly 80 power modules. Or the Audi centre in Bologna.

Big projects for JLR, Porsche, VW, Volvo, Mazda etc. throughout the world. We could easily continue this list. But apart from today's numerous success stories there is one unique success story which we would like to tell you. Especially because we were a part of it and have a common past.

An exceptional reference: the company group Senger

Short term successes are nice, but the best reference for us has been in the making for decades. Our company for lifting solutions was established in 1949, and in 1965 Egon Senger founded PERKUTE – his company which then later merged with autop, and which today is AUTOPSTENHOJ. This development has been an important milestone for us. This is a strong foundation. For more than 50 years Senger and autop have collaborated to form a strong partnership. A countless number of our lifts are working today in more than 39 locations of the Senger group with more than 3,000 employees.



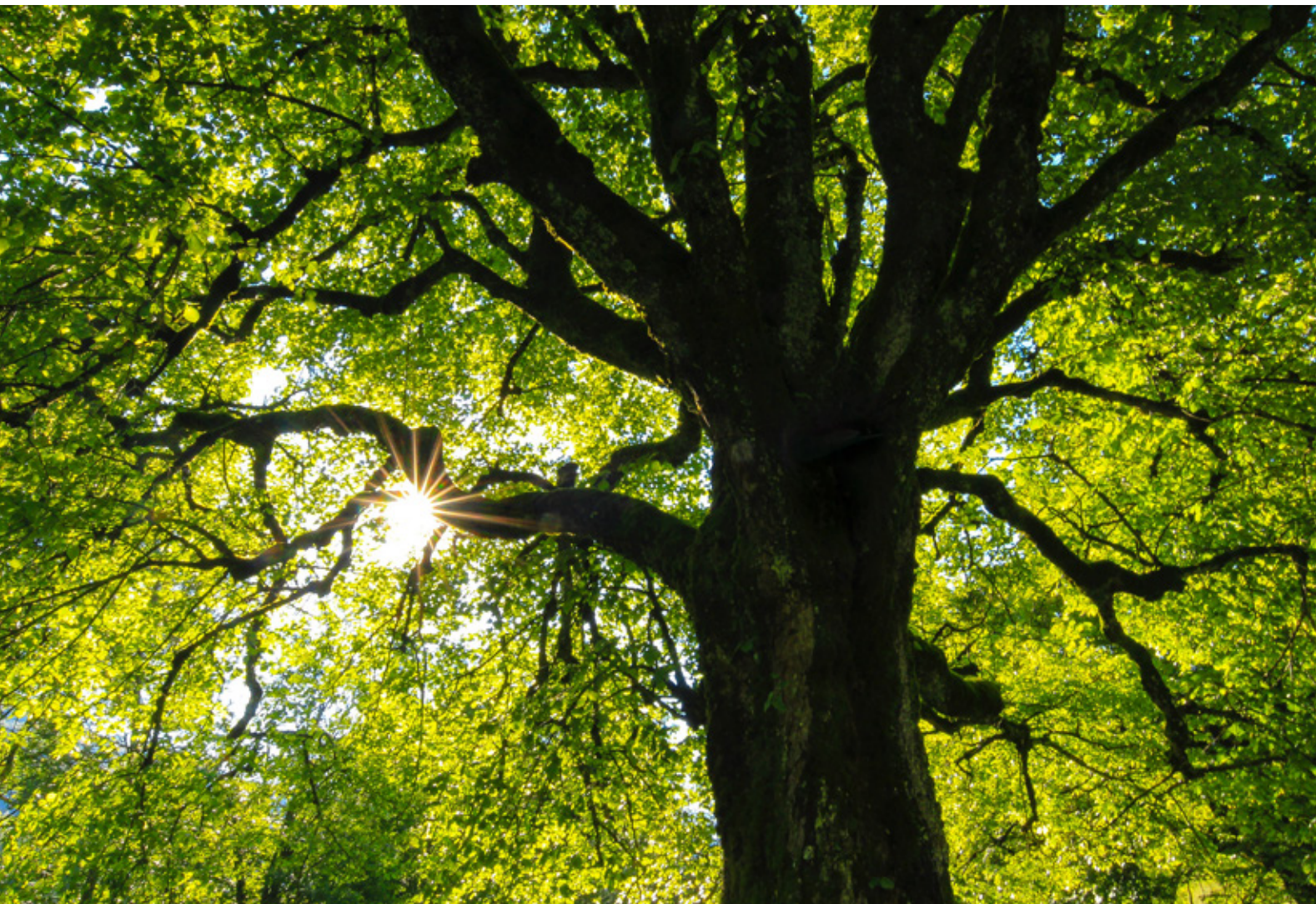

We have our environment in mind.

On the topic of the environment, AUTOPSTENHOJ has to show its true colours. There is no question about whether you act ecologically, but how far you are going with this important point. We answer this question for you when it comes to lifts by using environmentally friendly hydraulic fluid. This is our standard – no exceptions. And also – for example in Germany – you don't need to notify the installation of our hydraulic inground lifts to the official institutes. They correspond to the latest Water Management Acts. For you this means:

- You satisfy the demands of the water authority and environment agencies.
- You save extra audit fees.
- You avoid annoying questions in the building applications.
- You can rely on the recommendations of the leading car manufacturers.

Safety through high rate of water-tightness:

All our steel cassettes are liquid-tight, this fact is certified and documented with a name plate. This is the highest rate of tightness and comes at no extra charge. And at least for AUTOPSTENHOJ this is standard.

Safety through double-walled construction:

The whole hydraulic fluid chamber is located inside of the lifting equipment, which is installed in a liquid-tight cassette. This design is a double-walled construction for maximum safety and environmental compliance. In the unlikely event of leakage, the lift will stop within seconds and can no longer achieve maximum lifting height. Any leaking fluid is collected inside the liquid-tight cassette, so no contamination will occur.

Accordance with local, legal regulations:

Each lift has to be checked in structural construction. This also includes a check of cassettes. Hydraulic hoses should be changed every six years, a recommendation we make for the sake of the environment and our customers.

Maximum safety with minimum oil:

Our lifts only require very little hydraulic fluid to work safely and reliably. Lifts with a capacity of 3.5 t need only 8 to 10 liters of hydraulic fluid, higher capacities require a maximum of 17 liters.

Our advice for you: a simple change.

If your lifts are not filled with environmentally friendly liquid, we can advise you how to change it.

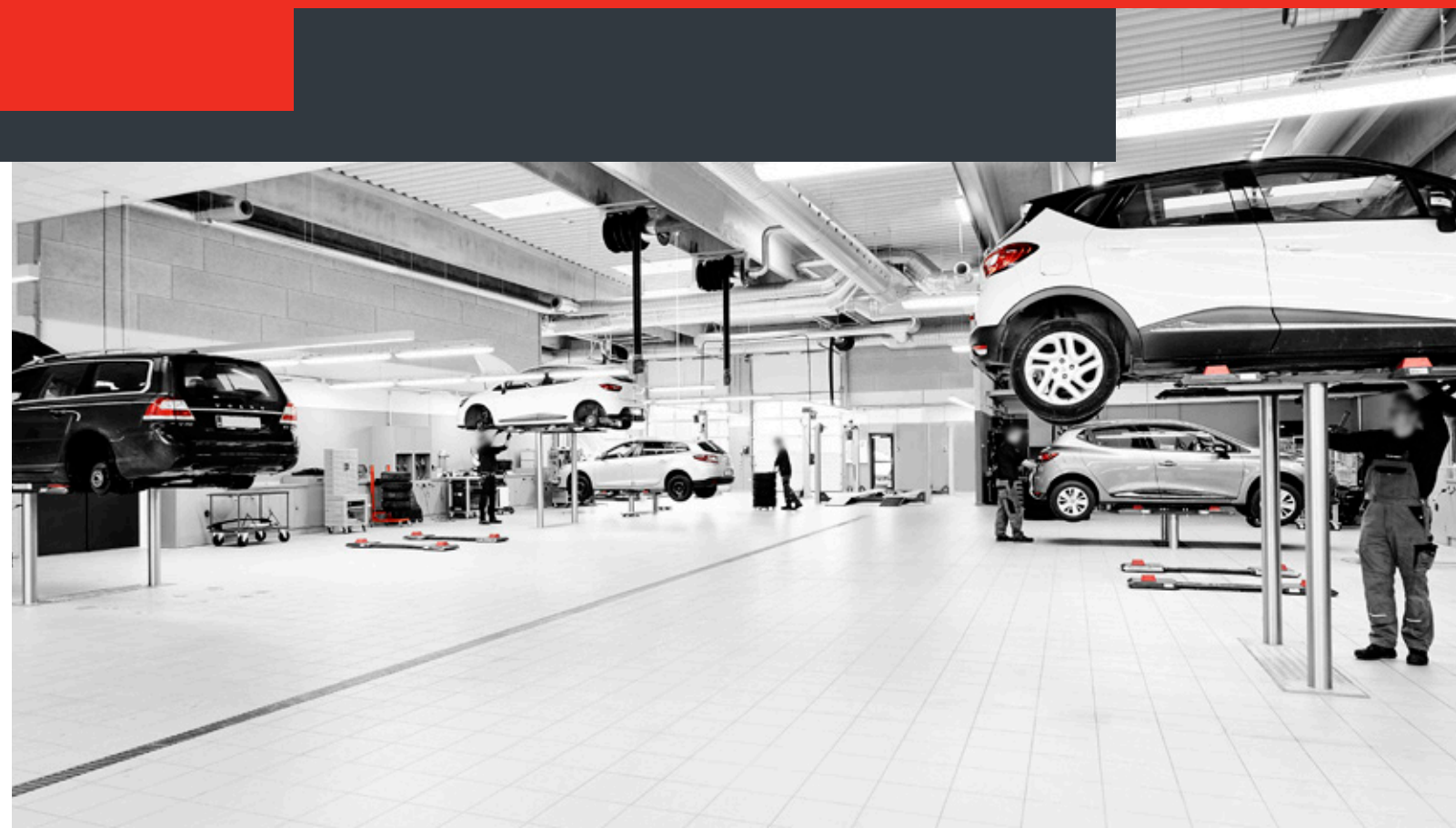



Our surface-mounted lifts.

Surface-mounted lifts

- **Product benefits / arguments**.....18
- **2-post lifts**.....22
 - Maestro 32.....22
 - Maestro 35.....24
 - Maestro 32 M.....26
 - Maestro 35 M.....28
 - Maestro 2.32.....30
 - Maestro 2.35 Premium.....32
 - Maestro 2.50.....34
 - Maestro 2.55.....36
 - Maestro 2.65.....38
 - Magnat 35.....40
 - Magnat 40.....42
 - Magnat 55.....44
- **4-ram lifts**.....46
 - Major 4026.....46
 - Major 4030.....48
 - Major 2.0 4030.....50
 - Major 4030-44 WL DLX.....52
 - Major 5030-53 Combi.....54
 - Major 5230.....56
 - Major 2.0 5531.....58
 - Major 5529-55 WL.....60
 - Major 6230.....62
 - Major 7230.....64
 - Major 4000-6000 MOT / ATL.....66
- **Scissor jacks**.....68
 - Micro 20 & 26 full hydraulic.....68
 - Micro 20 & 26 & 40 air hydraulic.....70
- **Scissor lifts**.....72
 - MagiX 30.....72
 - MagiX 35 LSMG II.....74
 - MagiX 35 DS.....76
 - MagiX 45.....78
 - MagiX 50.....80
- **Heavy duty lifts**.....82
 - Maxi 100.....82
 - Maxi 160, 200 & 240.....84
 - Micro 60-140.....86
 - Mobile 75 H + H WB.....88
- **Accessories**.....90
 - Lifting pads, rubber pads, wheel support devices.....90
 - Energy supply.....92
 - Jet Cleaner RC 82 / 122.....94



The sturdiest post on the market ...

We offer 5 years' warranty on spindles, nuts, seals and wires for our standard 2-post and 4-post lifts (except inspection models).*

*The warranty only applies if the annual maintenance has been carried out by trained specialist personnel and has been documented accordingly.

... shouldn't be hidden in the ground.

All our 2-post lifts are equipped with cold-rolled spindles with nut sets made in high quality nylon, guaranteeing very little tear and wear. Our posts, regardless of design are incredibly stable – to the benefit of all our customers.

Top quality is equal to a high degree of safety. Our surface-mounted lifts are naturally equipped with all necessary safety features.

The safety systems: There are quite a few.

You can rely on the many safety systems our surface-mounted lifts are equipped with:

- System against nut breakage
- Obstruction system
- Electronic synchronization
- Alarm signal
- Control unit with deadman-control and separate main switch

Small investment – many advantages.

- Low investment costs
- Many installation possibilities
- The right lift for the right purpose

From one advantage to the next.

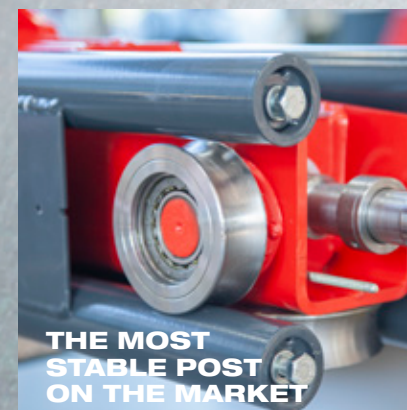



Your lifts are pillars of your workshop's success.

The surface-mounted lifts from AUTOPSTENHOJ offer almost as many models as the range of capacities. We offer everything from 2-post lifts with 3 t capacities to special solutions for e.g. a transporter with up to 7.2 t capacity. Our program offers possibilities for almost all weights and applications.

The main applications for our lifts are repair and maintenance, but we also focus on other areas such as check-in and wheel alignment. A good example of the latter is our Major 4030-44 WL DLX, which is the most precise wheel alignment lift on the market; and we are certain of that, as the lift complies with even the strictest demands from the car manufacturers.

Maestro 32

Electro-mechanical 2-post lift, 3.2 t capacity



Technical data	
Lifting capacity	3,200 kg
Lifting height	1,900 mm
Working height	1,995 - 2,025 mm
Lifting / lowering time	approx. 40 sec.
Motor	2 x 2.8 kW
Voltage	3 x 230/400V – 50 Hz – 25/16 A

Arm superstructure	
Lifting pad included in the delivery	F: 777112 (30 - 60 mm) CF: 777504 CF-08: 777395 + 660501
Min. height	95 mm
Drive-through width	2,110 – 2,310 mm
Width between posts	2,365 – 2,565 mm
Total width - outer edges posts	2,875 – 3,075 mm
Total width - outer edges base plates	3,120 – 3,320 mm
Total height post	2,706 mm
Total height incl. portal	4,050 / 4,350 mm
Arm length front, min. - max.	F DT: 540 – 850 mm
Arm length rear, min. - max.	F ST: 900 – 1,425 mm

Application

- Repair and maintenance

Approvals / recommendations

- BMW/Mini
- Volkswagen Group
- Renault

Description:

Posts:

- Asymmetric post installation
- Very stable bent posts
- Without base frame
- Two motors
- Cold-rolled spindle
- Nylon nut sets
- Carriage with a combination of bearing by sliding blocks and rollers
- Pushbutton control unit with alarm signal
- Programmable top stop
- Electronic synchronization

Arms:

- Front arms double and rear arms single telescopic
- Possibility of parallel parking of arms
- Internal arm locking system
- Low minimum height

Standard colours:

- Arms: RAL 3020 – red
- Posts: RAL 7016 – grey

Versions:

- Available with different voltages
- F = flex pad
- CF = combiflex pad
- CF-08 = combiflex 08 pad
- DT/ST = double telescopic short arms, single telescopic long arms

Optional extras:

- Available with different portal heights; alternatively in-ground kit
- LED-lighting set
- Power pack
- Set of expansion bolts
- Extra control unit
- Large program of extra pads

Special colours available on request!

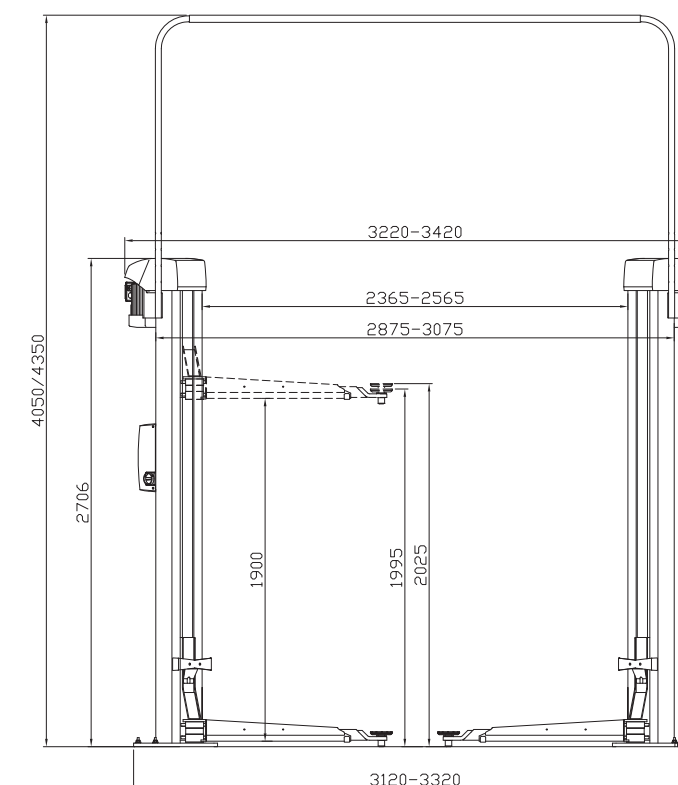

CF-pad / CF-08 pad / F-pad



Internal arm locking system

Maestro 35

Electro-mechanical 2-post lift, 3.5 t capacity



Technical data	
Lifting capacity	3,500 kg
Lifting height	1,900 mm
Working height	1,995 – 2,025 mm
Lifting / lowering time	approx. 40 sec.
Motor	2 x 2.8 kW
Voltage	3 x 400V – 50 Hz – 25 A

Arm superstructure	
Lifting pad included in the delivery	F: 777395 CF: 777505 CF-08: 660501 + 777395
Min. height	95 mm
Drive-through width	2,290 mm
Width between posts	2,565 mm
Total width - outer edges posts	3,075 mm
Total width - outer edges base plates	3,320 mm
Total height post	2,706 mm
Total height incl. portal	4,350 mm
Arm length front, min. - max.	F DT: 600 – 1,220 mm
Arm length rear, min. - max.	F ST: 900 – 1,425 mm

Application

- Repair and maintenance

Approvals / recommendations

- Maestro 35 CF DT: Volvo

Description:

Posts:

- Asymmetric post installation
- Very stable bent posts
- Without base frame
- Two motors
- Cold-rolled spindle
- Nylon nut sets
- Carriage with a combination of bearing by sliding blocs and rollers
- Pushbutton control unit with alarm signal
- Programmable top stop
- Electronic synchronization

Arms:

- Front arms double and rear arms single telescopic
- Possibility of parallel parking of arms
- Internal arm locking system
- Low minimum height

Standard colours:

- Arms: RAL 3020 – red
- Posts: RAL 7016 – grey

Versions:

- Available only with 400 V / 3 phases, 50 cycles
- F = flex pad
- CF = combiflex pad
- CF-08 = combiflex 08 pad
- DT/ST = double telescopic short arms, single telescopic long arms

Optional extras:

- Available with different portal heights; alternatively in-ground kit
- LED-lighting set
- Power pack
- Set of expansion bolts
- Extra control unit
- Extension set for 2.35 F Version
- Large program of extra pads

Special colours available on request!

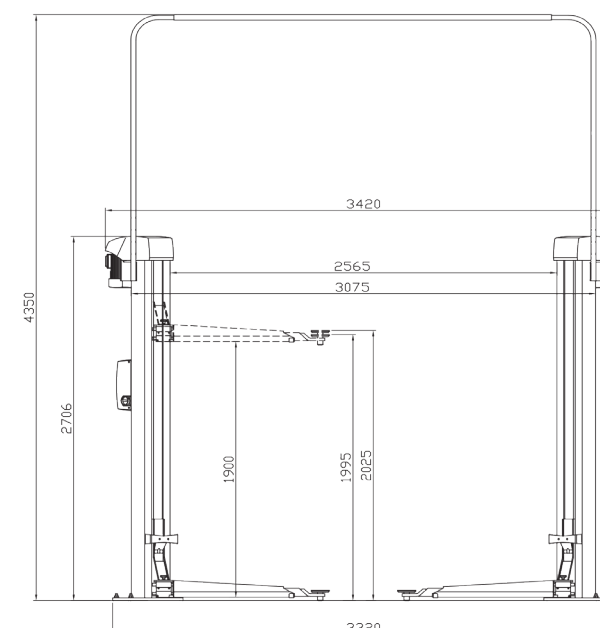

CF-pad / CF-08 pad / F-pad



Internal arm locking system

Maestro 32 M

Electro-mechanical 2-post lift, 3.2 t capacity

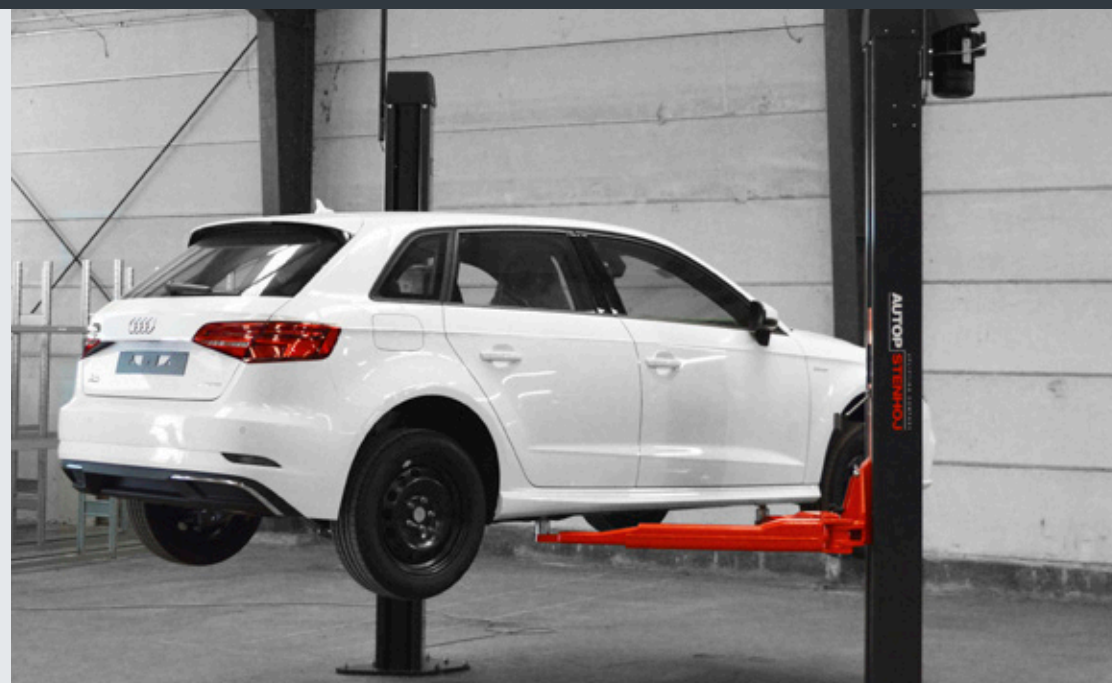

Technical data	
Lifting capacity	3,200 kg
Lifting height	1,900 mm
Working height	2,000 - 2,040 mm
Lifting / lowering time	approx. 35 sec.
Motor	2 x 2.8 kW
Voltage	3 x 230 / 400V - 50 Hz - 20 A

Arm superstructure	
Lifting pad included in the delivery	F: 11027: 100 - 140 mm
Height of plug-in in superstructure	F Standard: 53 mm
Min. height	88 mm (78 mm with extra lifting pad 29265)
Drive-through width	2,205 mm
Width between posts	2,565 mm
Total width - outer edges base plates	3,250 mm
Total height post	3,100 mm
Total height incl. portal	4,060 - 4,420 mm
Arm length front, min. - max.	F DT: 555 - 1,100 mm
Arm length rear, min. - max.	F DT: 555 - 1,100 mm

Application

- Repair and maintenance

Approvals / recommendations

- Volvo

Description:

Posts:

- Asymmetric post installation, vehicles can be positioned in rear area of work bay, for better door-opening angle
- Very stable bent posts
- Without base frame, therefore free drive-in situation
- Two strong electric motors
- Cold-rolled spindles for high durability
- Nylon nut sets for high durability
- Long carriage with optimized mounting of 8 sliding blocks for low friction
- Carriage with threaded holes for easy adoption of diverse superstructures
- Door-stop mounted on carriage
- Obstruction system for stopping the lift when it hits an obstacle
- Pushbutton control unit with alarm signal
- Programmable limit switch for top stop and CE-stop
- Electronic synchronization through comparison of pulses measured on the pulleys

Arms:

- Universal lifting area from small passenger car up to BMW series 7 long G12
- Possibility of parallel parking of arms for easier and faster positioning of vehicles
- Arms can be opened more than 180° for better drive-in situation (+45°) for lifts installed in 90° angle to the drive lane
- Low minimum height

Standard colours:

- Carriage and arms: RAL 3020 - red
- Posts: RAL 7016 - grey

Versions:

- Available with different voltages
- F = flex pad
- DT/DT = double telescopic short arms / double telescopic short arms

Optional extras:

- Available with different portal heights, alternatively inground kit
- Set of expansion bolts
- LED-lighting set, flexible with spiral cable, fastening through magnets on posts or vehicle
- Energy set with compressed air and socket-outlet
- Extra control unit for second post
- Large program of extra pads, depending on type of vehicle

Special colours available on request!

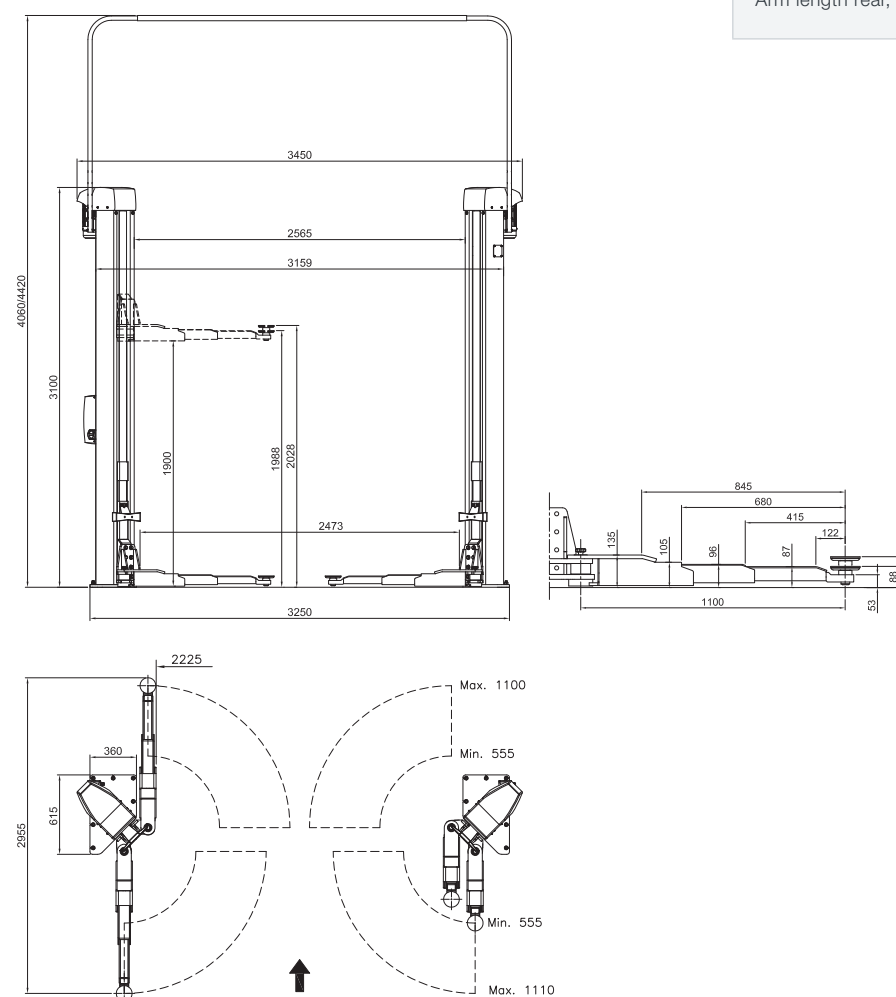

Pushbutton control unit with alarm signal



Arms can be opened more than 180° for better drive-in situation for lifts installed in 90° angle to the drive lane

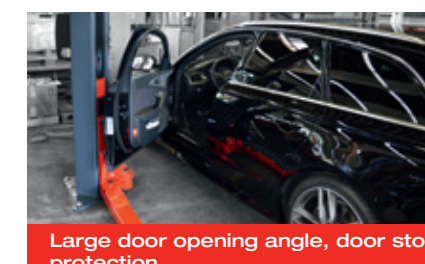

Large door opening angle, door stop protection

Maestro 35 M

Electro-mechanical 2-post lift, 3.5 t capacity



Technical data	
Lifting capacity	3,500 kg
Lifting height	1,900 mm
Working height	1,988 – 2,028 m
Lifting / lowering time	approx. 35 sec.
Motor	2 x 2.8 kW
Voltage	3 x 230 / 400V – 50 Hz – 20 A

Arm superstructure	
Lifting pad included in the delivery	F: 11027: 88 – 128 mm CF-08: 660501+777395 (95 - 250 mmm)
Height of plug-in in superstructure	F Premium: 53 mm
Min. height	F Premium: 88 mm (78 mm with extra lifting pad 29265)
Drive-through width	2,455 mm
Width between posts	2,815 mm
Total width - outer edges base plates	3,500 mm
Total height post	3,100 mm
Total height incl. portal	4,060 - 4,420 mm
Arm length front, min. - max.	F Premium DT: 555 – 1,100 mm
Arm length rear, min. - max.	F Premium: 925 – 1,550 mm

Application

- Repair and maintenance

Approvals / recommendations

- Volvo

Description:

Posts:

- Asymmetric post installation, vehicles can be positioned in rear area of work bay, for better door-opening angle
- Very stable bent posts
- Without base frame, therefore free drive-in situation
- Two strong electric motors
- Cold-rolled spindles for high durability
- Nylon nut sets for high durability
- Long carriage with optimized mounting of 8 sliding blocks for low friction
- Carriage with threaded holes for easy adoption of diverse superstructures
- Door-stop mounted on carriage
- Obstruction system for stopping the lift when it hits an obstacle
- Pushbutton control unit with alarm signal
- Programmable limit switch for top stop and CE-stop
- Electronic synchronization through comparison of pulses measured on the pulleys

Arms:

- Universal lifting area from small passenger car up to VW T6 long wheel base with lifting pad type „F“
- Possibility of parallel parking of arms for easier and faster positioning of vehicles
- Arms can be opened more than 180° for better drive-in situation (+45°) for lifts installed in 90° angle to the drive lane
- Low minimum height

Standard colours:

- Carriage and arms: RAL 3020 – red
- Posts: RAL 7016 – grey

Versions:

- Available with different voltages
- Premium arm set with special flat profile for sports cars
- F = flex pad
- CF-08 = combiflex-08 pad
- DT/- = double telescopic short arms / single telescopic long arms
- DT/DT = double telescopic short arms / double telescopic long arms

Optional extras:

- Available with different portal heights, alternatively inground kit
- Set of expansion bolts
- LED-lighting set, flexible with spiral cable, fastening through magnets on posts or vehicle
- Energy set with compressed air and socket-outlet
- Extra control unit for second post
- Large program of extra pads, depending on type of vehicle

Special colours available on request!

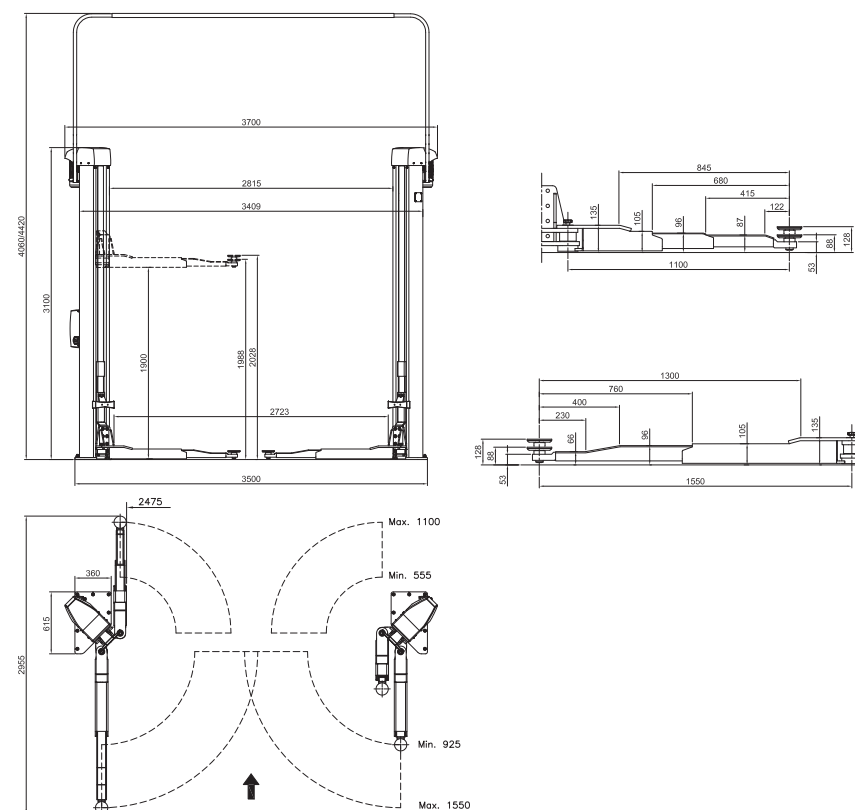

Pushbutton control unit with alarm signal



Arms can be opened more than 180° for better drive-in situation for lifts installed in 90° angle to the drive lane

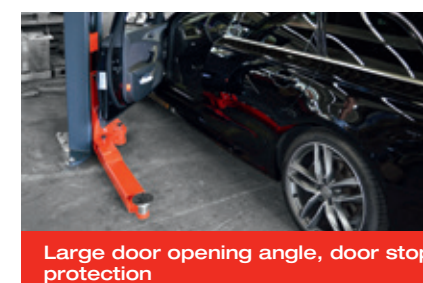

Large door opening angle, door stop protection

CF-08 pad / F pad

Maestro 2.32

Electro-mechanical 2-post lift, 3.2 t capacity



Technical data	
Lifting capacity	3,200 kg
Lifting height	1,900 mm
Working height	1,995 - 2,150 mm
Lifting / lowering time	approx. 40 sec.
Motor	2 x 1.5 kW
Voltage	3 x 230/400V - 50 Hz - 35/25 A

Arm superstructure	
Lifting pad included in the delivery	F: 777112 (95 - 125 mm) CF: 777504 (95 - 255 mm) CF-08: 777395 (95 - 250 mm)
Min. height	95 mm
Drive-through width	2,120 - 2,320 mm
Width between posts	2,380 - 2,580 mm
Total width - outer edges posts	2,960 - 3,160 mm
Total width - outer edges base plates	3,120 - 3,320 mm
Total height post	2,713 mm
Total height incl. portal	4,050/4,350 mm
Arm length front, min. - max.	F: 540 - 850 mm CF: 580 - 890 mm CF-08: 550 - 840 mm
Arm length rear, min. - max.	F: 900 - 1,425 mm CF: 935 - 1,425 mm CF-08: 920 - 1,415 mm

Application

- Repair and maintenance

Approvals / recommendations

- Renault

Description:

Posts:

- Asymmetric post installation
- Very stable welded posts
- Without base frame
- Two motors
- Cold-rolled spindle
- Nylon nut sets
- Carriage with 6 guiding wheels and lubrication-free roller bearings
- Pushbutton control unit with alarm signal
- Programmable top stop
- Electronic synchronization

Arms:

- Single telescopic front and rear arms, as standard
- Possibility of parallel parking of arms
- Internal arm locking system
- Low minimum height

Standard colours:

- Arms: RAL 3020 - red
- Posts: RAL 7016 - grey

Versions:

- Available with different voltages
- F = flex pad
- CF = combiflex pad
- CF-08 = combiflex 08 pad

Optional extras:

- Available with 2 different portal heights; alternatively in-ground kit
- LED-lighting set
- Power pack
- Set of expansion bolts
- Extra control unit
- Long door stops
- Wheel holders
- Large program of extra pads

Special colours available on request!

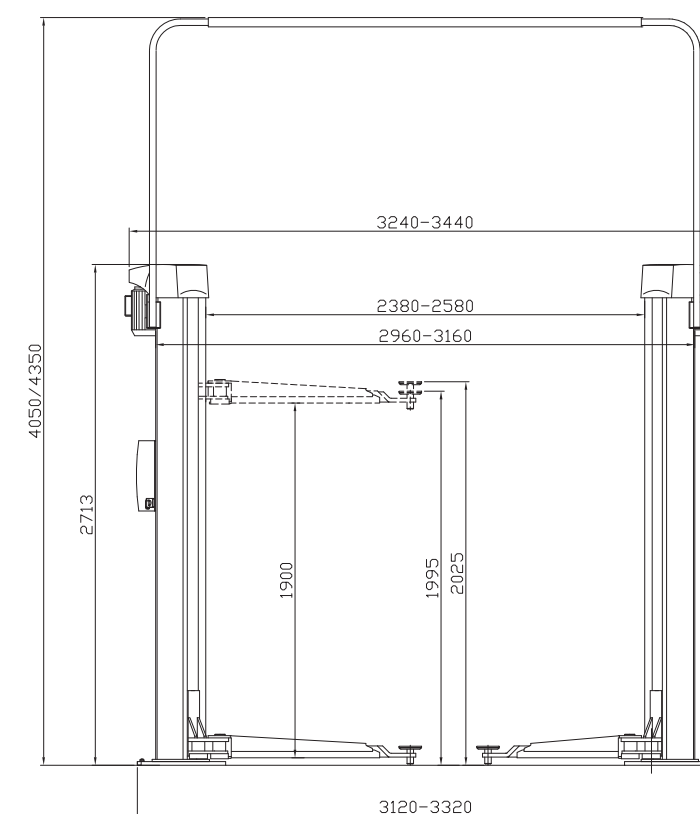

CF-pad / CF-08 pad / F-pad



Stable, welded post

Maestro 2.35 Premium

Electro-mechanical 2-post lift, 3.5 t capacity



Technical data	
Lifting capacity	3,500 kg
Lifting height	1,900 mm
Working height	1,970 – 2,035 mm + 65 mm pad extensions
Lifting / lowering time	approx. 35 sec.
Motor	2 x 2.8 kW
Voltage	3x230/400 V-50Hz - 20A

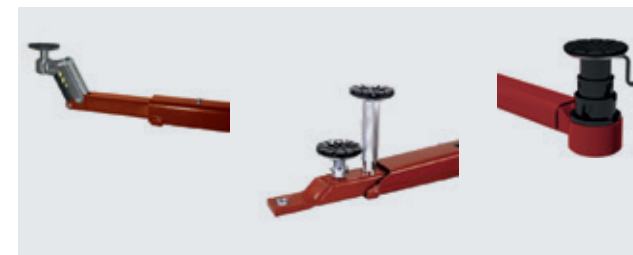

CF-pad / F-pad / CF-08 pad

Arm superstructure	
Lifting pad included in the delivery	F: 29265 (70 - 95 mm) CF: 777560 (88 - 255 mm) CF-08: 660501 + 777395 (97 - 208 mm)
Insertion height in arm	F Premium: 44 mm
Min. height	70 mm + 65 mm pad extensions
Drive-through width	DT/DT: 2,216 mm DT/ST: 2,466 mm ST/ST: 2,466 mm
Width between posts	DT/DT: 2,509 mm DT/ST: 2,759 mm ST/ST: 2,759 mm
Total width - outer edges base plates	DT/DT: 3,250 mm DT/ST: 3,500 mm ST/ST: 3,500 mm
Total height post	2,713 mm
Total height incl. Portal	3,990 - 4,350 mm
Arm length front, min. - max.	DT: 555 - 1.100 mm ST: 925 - 1.550 mm
Arm length rear, min. - max.	DT: 555 - 1.100 mm ST: 925 - 1.550 mm

Application

- Repair and maintenance

Description:

Posts:

- Asymmetric post installation, vehicles can be positioned in rear area of work bay, for better door-opening angle
- Very stable welded posts
- Without base frame, therefore free drive-in situation
- Two strong electric motors
- Cold-rolled spindles for high durability
- Nylon nut sets for high durability
- Carriage with 6 guiding wheels and lubrication-free roller bearings, for very low friction
- Door-stop mounted on carriage
- Obstruction system for stopping the lift when it hits an obstacle
- Pushbutton control unit with alarm signal
- Programmable limit switch for top stop and CE-stop
- Electronic synchronization through comparison of pulses on both columns

Arms:

- Arms DT/ST: Universal lifting area from small passenger car up to VW T6 long wheel base with lifting pad type „F“
- Arms DT/DT: Universal lifting area from small passenger car up to BMW 7 series long (G12) with lifting pad type „F“
- Possibility of parallel parking of arms for easier and faster positioning of vehicles
- Arms can be opened more than 180° for better drive-in situation (+45°) for lifts installed in 90° angle to the drive lane
- Internal arm locking system, protected against moisture and dirt, with strong 360° interlocking
- Low minimum height

Standard colours:

- Carriage and arms: RAL 3020 – red
- Posts: RAL 7016 – grey

Versions:

- Available with different voltages
- F = flex pad
- CF = combiflex pad
- CF-08 = combiflex-08 pad
- DT/ST = double telescopic short arms in front / single telescopic long arms in rear
- DT/DT = double telescopic short arms in front and rear
- ST/ST = single telescopic long arms in front and rear

Optional extras:

- Available with different portal heights, alternatively inground kit
- Set of expansion bolts
- LED-lighting set
- Energy set with compressed air and socket-outlet
- Extra control unit for second column
- Wheel supports
- Large program of extra pads, depending on type of vehicle

Special colours available on request!

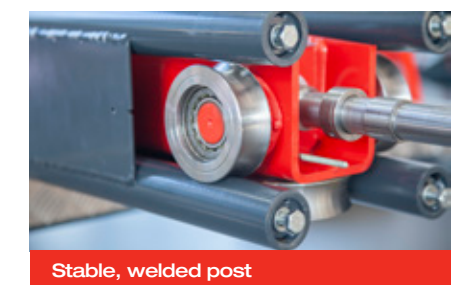
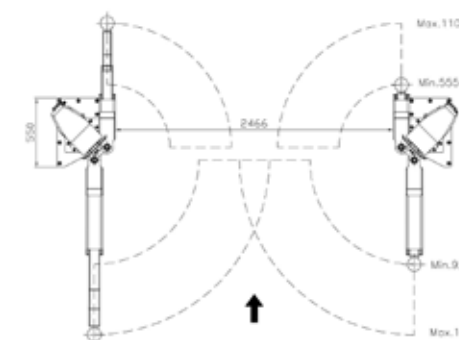
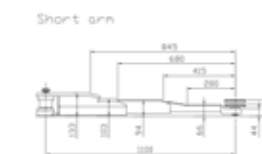
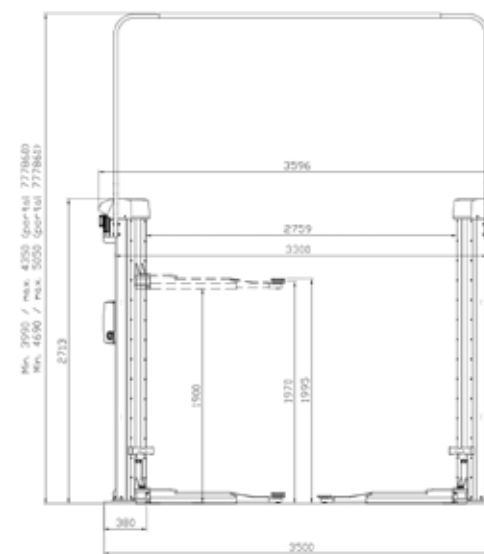

Stable, welded post



Internal arm locking system

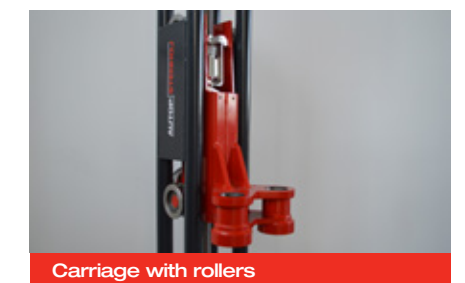

Carriage with rollers

Maestro 2.50

Electro-mechanical 2-post lift, 5 t capacity



Technical data	
Lifting capacity	5,000 kg
Lifting height	1,900 mm
Working height	F Sport: 2,022 – 2,052 mm FL: 2,040 - 2,070 mm
Lifting / lowering time	approx. 55 sec.
Motor	2 x 2.8 kW
Voltage	3 x 230/400V – 50 Hz – 35/25 A

Arm superstructure	
Lifting pad included in the delivery	F: 770505 (30 – 60 mm)
Min. height	F Sport: 122 mm FL: 140 mm
Drive-through width	2,800 – 3,000 mm
Width between posts	3,185 – 3,385 mm
Total width - outer edges posts	3,560 – 3,760 mm
Total width - outer edges base plates	3,910 – 4,110 mm
Total height post	2,908 mm
Total height incl. portal	4,910 – 5,270 mm
Arm length front, min. - max.	F Sport: 875 – 1,930 mm FL: 957 – 2,138 mm
Arm length rear, min. - max.	F Sport: 875 – 1,930 mm FL: 957 – 2,138 mm

Application

- Repair and maintenance

Approvals / recommendations

- BMW / Mini
- Renault
- Rolls-Royce

Description:

Posts:

- Symmetric post installation
- Very stable welded posts
- Without base frame
- Two motors
- Cold-rolled spindle
- Nylon nut sets
- Carriage with 6 guiding wheels and lubrication-free roller bearings
- Pushbutton control unit with alarm signal
- Programmable top stop
- Electronic synchronization

Arms:

- 4 double telescopic arms
- Internal arm locking system
- Low minimum height

Standard colours:

- Arms: RAL 3020 – red
- Posts: RAL 7016 – grey

Versions:

- Available with different voltages
- F = flex pad
- L = long arms

Optional extras:

- Available with portal or in-ground kit
- LED-lighting set
- Power pack
- Set of expansion bolts
- Extra control unit
- Long door stops
- Wheel holders
- Set of 4 wheel forks (400 mm)
- Large program of extra pads

Special colours available on request!

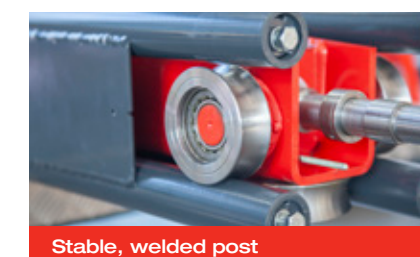
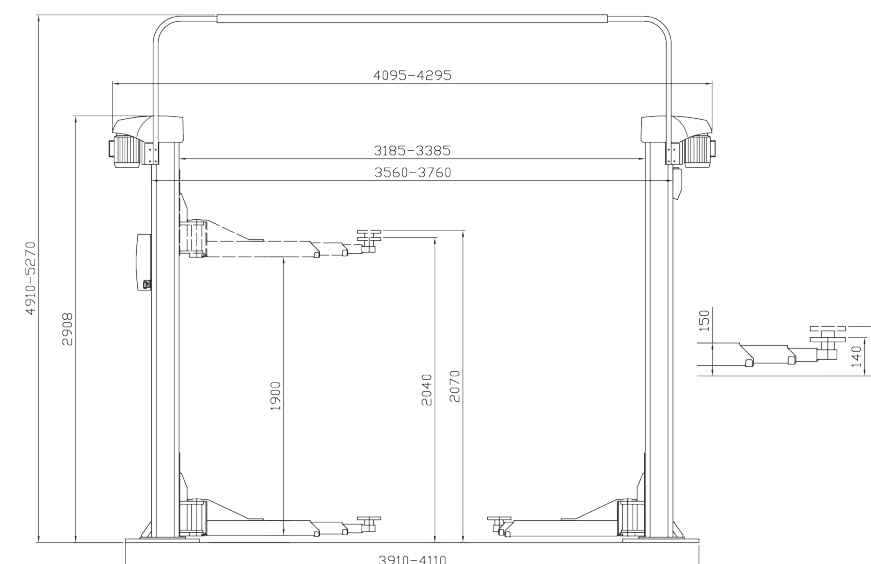

Stable, welded post



Double telescopic arms with F-Pad



Nylon nut sets

Maestro 2.55

Electro-mechanical 2-post lift, 5.5 t capacity



Technical data	
Lifting capacity	5,500 kg
Lifting height	1,900 mm
Working height	2,040 – 2,070 mm
Lifting / lowering time	approx. 55 sec.
Motor	2 x 2.8 kW
Voltage	3 x 230/400V – 50 Hz – 35/25 A

Arm superstructure	
Lifting pad included in the delivery	F: 770505 (30 – 60 mm)
Min. height	140 mm
Drive-through width	2,800 – 3,000 mm
Width between posts	3,185 – 3,385 mm
Total width - outer edges posts	3,560 – 3,760 mm
Total width - outer edges base plates	3,910 – 4,110 mm
Total height post	2,908 mm
Total height incl. portal	4,910 – 5,270 mm
Arm length front, min. - max.	957 – 1,900 mm
Arm length rear, min. - max.	957 – 1,900 mm

Application

- Repair and maintenance

Approvals / recommendations

- Volkswagen Group

Description:

Posts:

- Symmetric post installation
- Very stable welded posts
- Without base frame
- Two motors
- Cold-rolled spindle
- Nylon nut sets
- Carriage with 6 guiding wheels and lubrication-free roller bearings
- Pushbutton control unit with alarm signal
- Programmable top stop
- Electronic synchronization

Arms:

- 4 double telescopic arms
- Internal arm locking system
- Low minimum height

Standard colours:

- Arms: RAL 3020 – red
- Posts: RAL 7016 – grey

Versions:

- Available with different voltages
- F = flex pad

Optional extras:

- Available with portal or in-ground kit
- LED-lighting set
- Power pack
- Set of expansion bolts
- Extra control unit
- Long door stops
- Wheel holders
- Large program of extra pads

Special colours available on request!

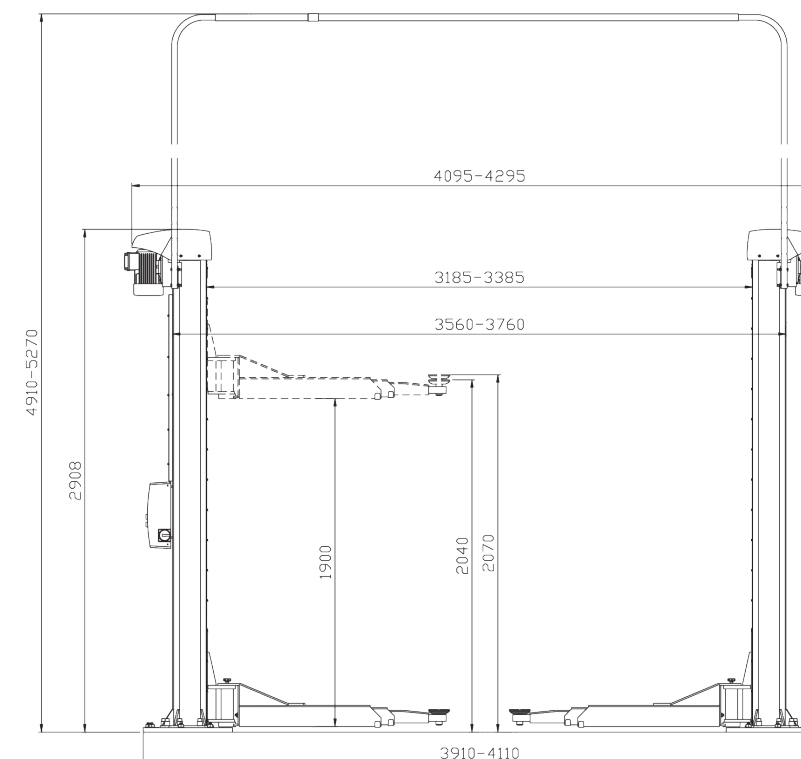

F-Pad

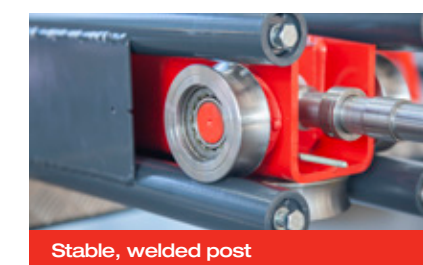

Stable, welded post



Carriage with rollers

Maestro 2.65

Electro-mechanical 2-post lift, 6.5 t capacity



Technical data	
Lifting capacity	6,500 kg
Lifting height	1,900 mm
Working height	2,045 – 2,105 mm
Lifting / lowering time	approx. 35 sec.
Motor	2 x 4 kW
Voltage	3 x 230/400V – 50 Hz – 35/25 A

Arm superstructure	
Lifting pad included in the delivery	F: 11028 (90 – 150 mm)
Min. height	145 mm
Drive-through width	2,829 mm
Width between posts	3,170 mm
Total width - outer edges posts	3,560 mm
Total width - outer edges base plates	4,000 mm
Total height post	2,908 mm
Total height incl. portal	4,910 – 5,270 mm
Arm length front, min. - max.	770 – 1,640 mm
Arm length rear, min. - max.	770 – 1,640 mm

Application

- Repair and maintenance

Approvals / recommendations

- Mercedes-Benz
- Volkswagen Group

Description:

Posts:

- Symmetric post installation
- Very stable welded posts
- Without base frame
- Two motors
- Cold-rolled spindle
- Nylon nut sets
- Carriage with 6 guiding wheels and lubrication-free roller bearings
- Pushbutton control unit with alarm signal
- Programmable top stop
- Electronic synchronization

Arms:

- 4 triple telescopic arms
- Wheel bearing of the first extension arm
- Low minimum height

Standard colours:

- Arms: RAL 3020 – red
- Posts: RAL 7016 – grey

Versions:

- Available with different voltages
- F = flex pad

Optional extras:

- Available with portal or in-ground kit
- LED-lighting set
- Power pack
- Set of expansion bolts
- Extra control unit
- Long door stops
- Wheel holders
- Large program of extra pads

Special colours available on request!

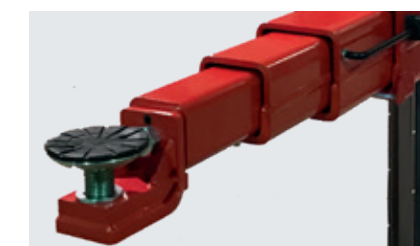
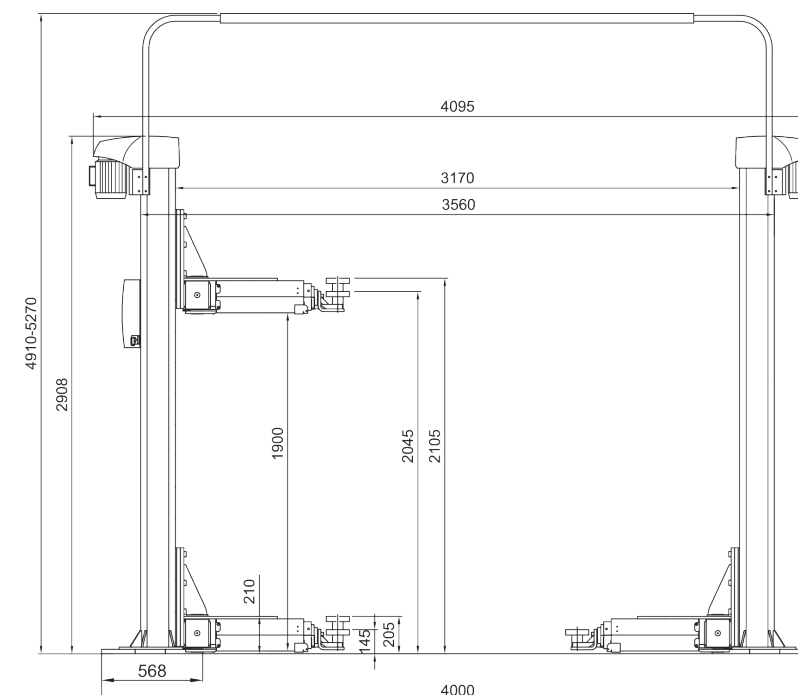

Triple telescopic arms with F-pad



Stable, welded post



Carriage with rollers

Magnat 35

Electro-hydraulic 2-post lift, 3.5 t capacity



Technical data	
Lifting capacity	3,500 kg
Lifting height	1,800 mm
Working height	1,940 mm
Lifting / lowering time	30 sec.
Pump unit	2.2 kW
Voltage	3x230 / 400 V-50 / 60Hz – 16 A

Arm superstructure	
Lifting pad included in the delivery	F: 95 – 140 mm
Min. height	95 mm
Drive-through width	BMW: 2,250 mm Uni: 2,450 mm
Width between posts	BMW: 2,560 mm Uni: 2,760 mm
Total width - outer edges base plates	BMW: 3,245 mm Uni: 3,495 mm
Total height incl. portal	4,009 mm + 250 mm
Arm length front, min. - max.	F BMW: 590 – 995 mm F Uni: 640 – 1,145 mm
Arm length rear, min. - max.	F BMW: 710 – 1,275 mm F Uni: 880 – 1,560 mm

Application

- Repair and maintenance

Approvals / recommendations

- Volkswagen Group
- Volvo

Description:

Posts:

- Vehicle rear positioning for optimum door opening angle
- Very stable bent posts
- Without base frame
- One hydraulic unit
- Carriage with slide blocks
- Pushbutton control unit with alarm signal stop and upper protection list
- Mechanic synchronization
- Safety ratchet system no expensive compressed air required
- Post is height adjustable during installation

Arms:

- Double telescopic front and rear arms, as standard
- Possibility of parallel parking of arms
- Automatic arm locking system
- Low minimum height
- Suitable for the smallest passenger cars up to T6 long
- Parallel-parking of arms eases positioning

Standard colours:

- Arms: RAL 3020 – red
- Posts: RAL 7016 – grey

Versions:

- Available with different voltages
- BMW- and Universal armset available
- FD BMW
- FD Uni

Optional extras:

- Set of expansion bolts
- A large program of lifting pads
- Portal can during installation be fitted in 2 different heights
- Adaptor for AUTOPSTENHOJ pads

Special colours available on request!

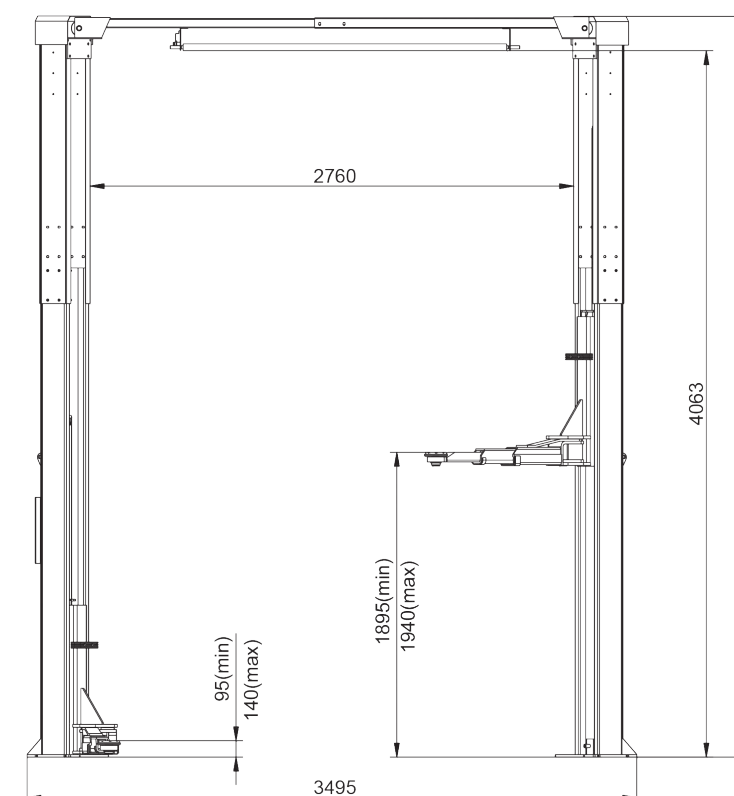

Swivel arm positioning > 180° for better drive-in situation



Low arm construction <100mm

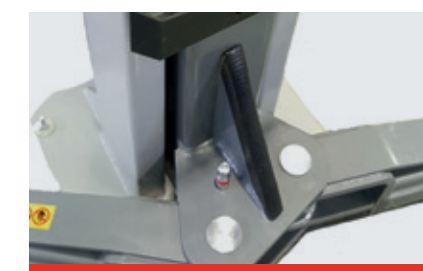

Arm locking system and door protection

Magnat 40

Electro-hydraulic 2-post lift, 4 t capacity



Technical data	
Lifting capacity	4,000 kg
Lifting height	1,800 mm
Working height	1,940 mm
Lifting / lowering time	30 sec.
Pump unit	2.2 kW
Voltage	3x230/400 V - 50/60Hz - 16 A

Arm superstructure	
Lifting pad included in the delivery	F: 95 – 140 mm
Min. height	95 mm
Drive-through width	Uni: 2,450 mm
Width between posts	Uni: 2,760 mm
Total width - outer edges base plates	Uni: 3,495 mm
Total height incl. portal	4,009 mm + 250 mm
Arm length front, min. - max.	F Uni: 640 – 1,145 mm
Arm length rear, min. - max.	F Uni: 880 – 1,560 mm

Application

- Repair and maintenance

Description:

Posts:

- Vehicle rear positioning for optimum door opening angle
- Very stable bent posts
- Without base frame
- One hydraulic unit
- Carriage with slide blocks
- Pushbutton control unit with alarm signal stop and upper protection list
- Mechanic synchronization
- Safety ratchet system no expensive compressed air required
- Post is height adjustable during installation

Arms:

- Double telescopic front and rear arms, as standard
- Possibility of parallel parking of arms
- Automatic arm locking system
- Low minimum height
- Suitable for the smallest passenger cars up to T6 long
- Parallel-parking of arms eases positioning

Standard colours:

- Arms: RAL 3020 – red
- Posts: RAL 7016 – grey

Versions:

- Available with different voltages
- BMW- and Universal armset available
- FD BMW
- FD Uni

Optional extras:

- Set of expansion bolts
- A large program of lifting pads
- Portal can during installation be fitted in 2 different heights
- Adaptor for AUTOPSTENHOJ pads

Special colours available on request!

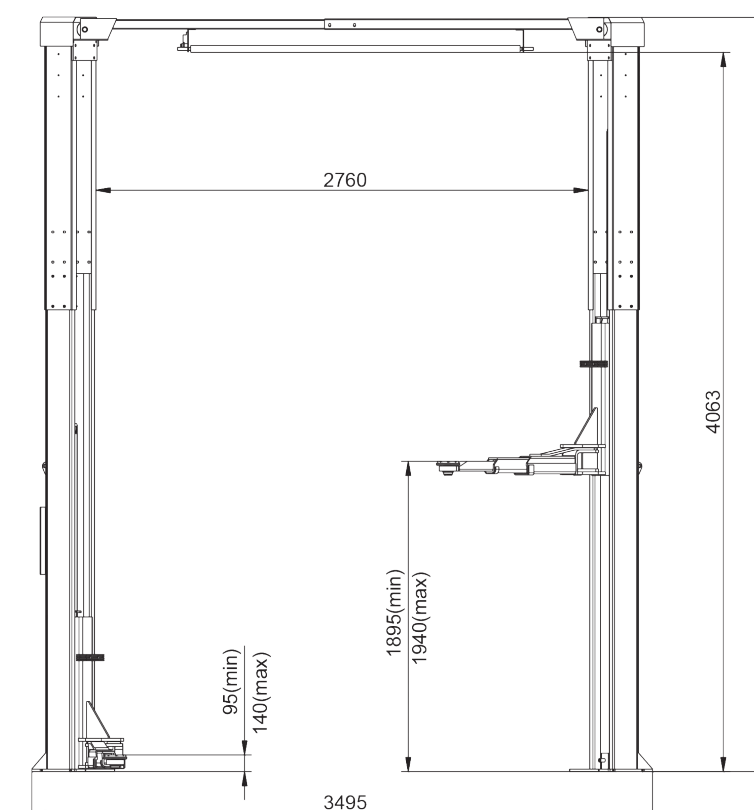

Magnat 55

Electro-hydraulic 2-post lift, 5.5 t capacity

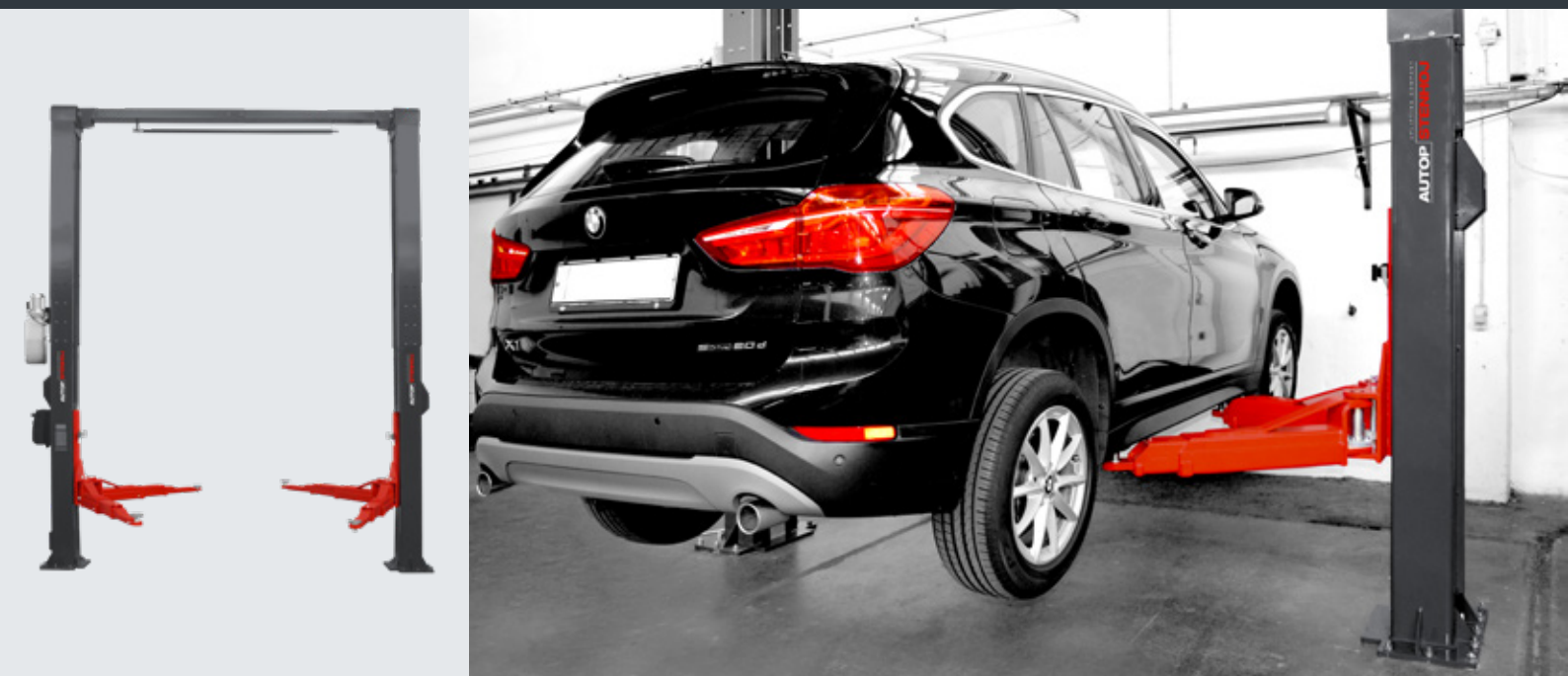

Technical data	
Lifting capacity	5,500 kg
Lifting height	1,800 mm
Working height	1,900 - 1,940 mm
Lifting / lowering time	42 sec.
Pump unit	3.6 kW
Voltage	3x230/400 V - 50/60Hz - 16 A

Arm superstructure	
Lifting pad included in the delivery no. 11081	100 - 140 mm
Min. height	100 mm
Drive-through width	2,900 mm
Width between posts	3,330 mm
Total width - outer edges base plates	3,992 mm
Total height incl. portal	4,915 mm
Arm length front/rear, min. - max.	850 - 1,820 mm

Application

- Repair and maintenance

Description:

Posts:

- Symmetric posts
- Very stable bent posts
- Without base frame
- One hydraulic unit
- Carriage with slide blocks
- Pushbutton control unit with alarm signal
- Adjustable end stop and upper protection bar
- Mechanic synchronization
- Electrical safety ratchet system no expensive compressed air required

Arms:

- Double telescopic front and rear arms, as standard
- Automatic arm locking system
- Low minimum height
- Suitable for passenger cars up to big vans and transposters

Standard colours:

- Arms: RAL 3020 - red
- Posts: RAL 7016 - grey

Versions:

- Available with different voltages
- Universal armset

Optional extras:

- Set of expansion bolts
- A large program of lifting pads

Special colours available on request!

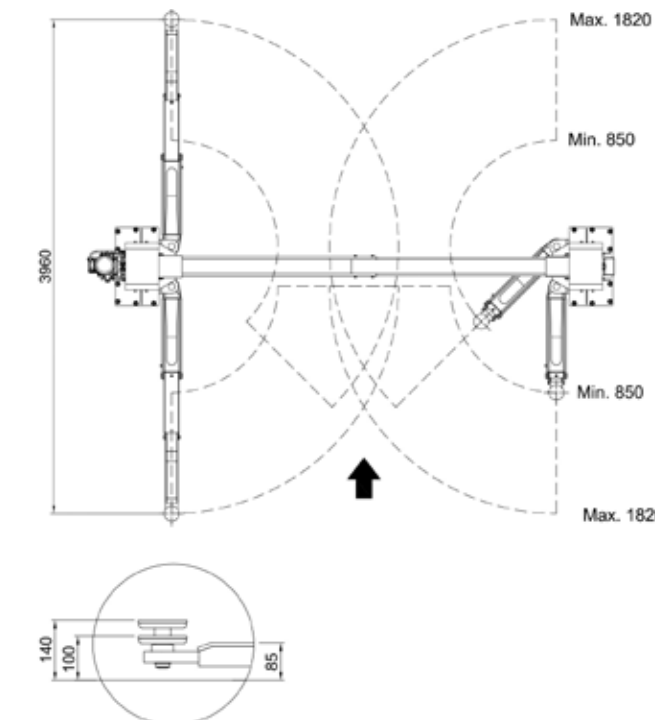
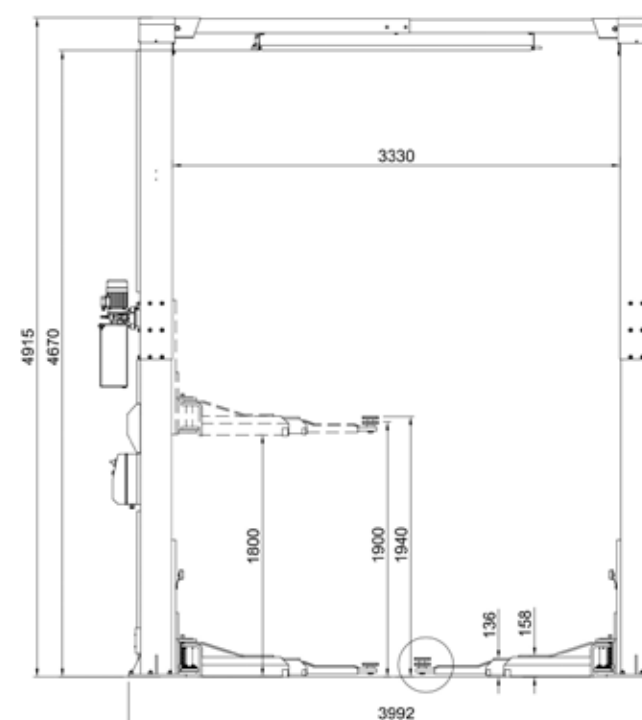

Flat double telescopic arms



Good lifting area



Door protection

Major 4026

Electro-hydraulic 4-post lift, 4 t capacity



Technical data	
Lifting capacity	4,000 kg
Lifting height	1,670 mm
Working height	1,810 mm
Lifting / lowering time	Standard: 24 / 26 sec. D: 16 / 26 sec.
Pump unit	Standard: 3 kW D: 2 x 3 kW
Voltage	3x230 / 400V – 50 Hz - 25 / 16 A

Platforms	
Total length	5,060 / 5,560 mm
Usable length of platform	4,180 / 4,680 mm
Wheel base, min. - max.	variable
Platform width	500 mm
Distance between platforms	740 – 1,030 mm
Min. height	140 / 160 mm
Width between posts	2,600 mm
Total width - outer edges base plates	3,022 mm
Total height	2,233 mm

Also available as inspection lifts:

As standard equipped with re-inforced posts and larger cable diameter for intensive usage in inspection centres. As standard delivered with:

P = play detector (pneumatically operated for both lateral and rotational movement, for axle load up to 3 t), operation with wireless hand lamp

Option:

D = double pump unit for quicker lifting time. Control unit on front left post

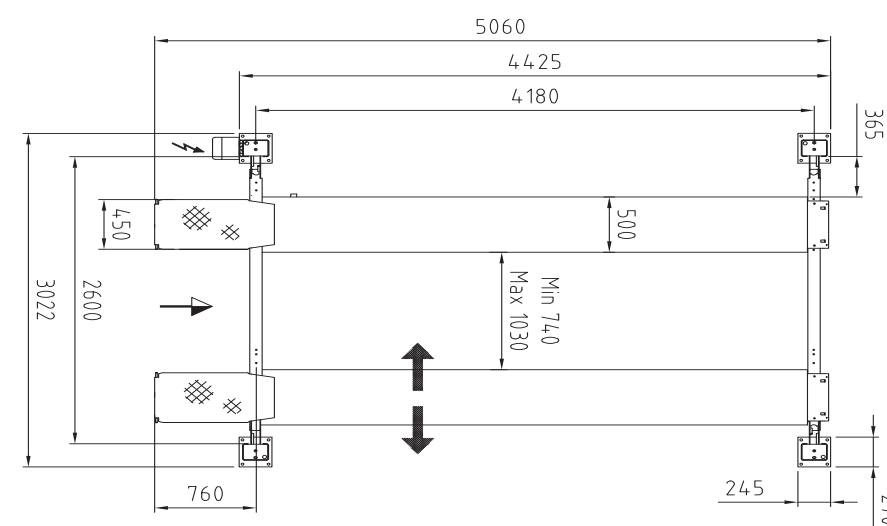

Ratchet for parking position



Control unit and power pack on rear left post



Pulley with steel cable

Application

- Check-in
- Repair and maintenance
- Wheel alignment
- Testing

Approvals / recommendations

- Major 4026-47 S: Volvo
- Major 4026-47 W: Volvo

Description:

Posts:

- Integrated eccentric brake system
- Emergency stop valve
- Obstruction system
- Pneumatic parking system in height adjustable ratchets
- Pump unit with immersed motor and control unit on rear left post
- Pushbutton control unit with alarm signal
- Hydraulic cylinder under left platform
- Lifting and lowering by means of cables
- Emergency lowering valve

Platforms:

- One moveable platforms as standard
- Platforms prepared for AUTOPSTENHOJ scissor jack

Standard colours:

- Platforms & posts: RAL 7016 – grey
- Ramps: RAL 3020 – red

Versions:

- Available with different voltages
- Drive-on ramps and stops for surface-mounting, alternatively drive-over ramps for recessed installation
- S = flush platforms
- W = with front recesses for turn tables and rear side slip plates
- G = galvanized platforms
- 42 = 4,200 mm platforms
- 47 = 4,700 mm platforms
- 51 = 5,100 mm platforms

Optional extras:

- Set of expansion bolts
- Extra control unit
- LED-lighting set
- Set of two cover plates for recesses
- Set of two 385 mm ramp extensions
- Set of two platform extensions (0.5 m)

Special colours available on request!

Major 4030

Electro-hydraulic 4-post lift, 4 t capacity



Technical data	
Lifting capacity	4,000 kg
Lifting height	1,670 mm
Working height	1,810 mm
Lifting / lowering time	Standard: 24 / 26 sec. D: 16 / 26 sec.
Pump unit	Standard: 3 kW D: 2 x 3 kW
Voltage	3x230 / 400V – 50 Hz – 25 / 16 A

Platforms	
Total length	5,560 / 5,980 mm
Usable length of platform	4,680 / 5,100 mm
Wheel base, min. - max.	variable
Platform width	550 mm
Distance between platforms	805 – 1,285 mm
Min. height	140 / 160 mm
Width between posts	3,000 mm
Total width - outer edges base plates	3,422 mm
Total height	2,233 mm

Also available as inspection lifts:

As standard equipped with re-inforced posts and larger cable diameter for intensive usage in inspection centres. As standard delivered with:

P = play detector (pneumatically operated for both lateral and rotational movement, for axle load up to 3 t), operation with wireless hand lamp

Option:

D = double pump unit for quicker lifting time. Control unit on front left post

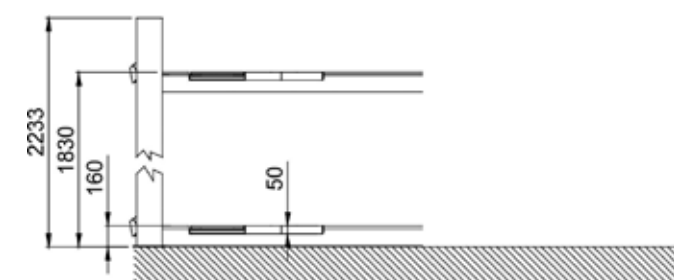
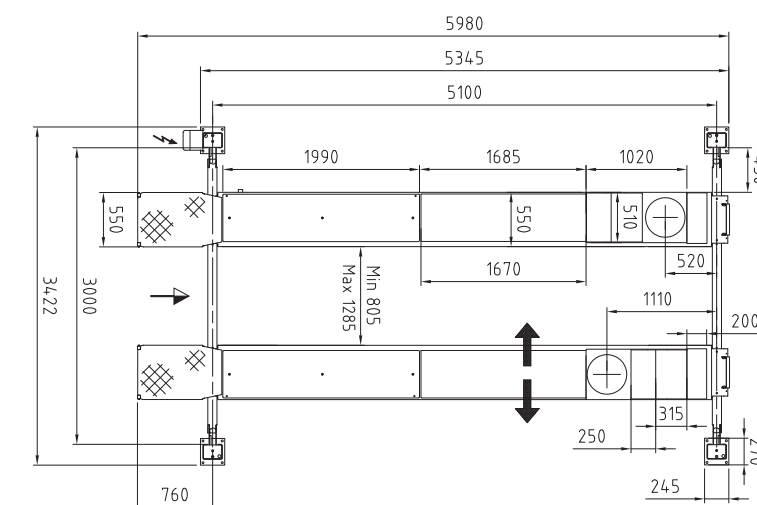

Ratchet for parking position



Control unit and power pack on rear left post

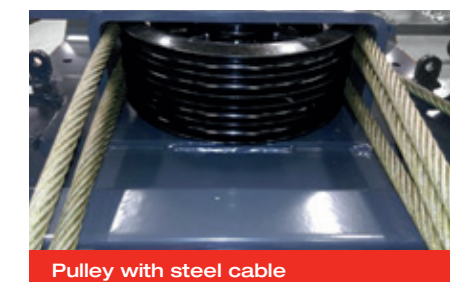

Pulley with steel cable

Application

- Check-in
- Repair and maintenance
- Wheel alignment
- Testing

Approvals / recommendations

- Jaguar
- Landrover
- Renault
- Volvo

Description:

Posts:

- Integrated eccentric brake system
- Emergency stop valve
- Obstruction system
- Pneumatic parking system in height adjustable ratchets
- Pump unit with immersed motor and control unit on rear left post
- Pushbutton control unit with alarm signal
- Hydraulic cylinder under left platform
- Lifting and lowering by means of cables
- Emergency lowering valve

Platforms:

- One moveable platforms as standard
- Platforms prepared for AUTOPSTENHOJ scissor jack

Standard colours:

- Platforms & posts: RAL 7016 – grey
- Ramps: RAL 3020 – red

Versions:

- Available with different voltages
- Drive-on ramps and stops for surface-mounting, alternatively drive-over ramps for recessed installation
- S = flush platforms
- WL = with front recesses for turn tables and rear side slip plates, center cover plate between recesses and side slip plates
- G = galvanized platforms
- 42 = 4,200 mm platforms
- 47 = 4,700 mm platforms
- 51 = 5,100 mm platforms

Optional extras:

- Set of expansion bolts
- Extra control unit
- LED-lighting set
- Set of two cover plates for recesses
- Set of two 385 mm ramp extensions
- Set of two platform extensions (0.5 m)

Special colours available on request!

Major 2.0 4030

Electro-hydraulic 4-post lift, 4 t capacity



Technical data	
Lifting capacity	4,000 kg
Lifting height	1,670 mm
Working height	1,860 mm
Lifting / lowering time	Standard: 24 / 26 sec.
Pump unit	Standard: 3 kW
Voltage	3x230 / 400V – 50 Hz – 25 / 16 A

Platforms	
Total length	51: 5,983 mm
Usable length of platform	51: 5,100 mm
Wheel base, min. - max.	51 S: max. 4,600 mm 51 WL: min. 2,100 mm, max. 4,100 mm
Platform width	550 mm
Distance between platforms	805 – 1,285 mm
Min. height	190 mm
Width between posts	3,000 mm
Total width - outer edges base plates	3,422 mm
Total height	2,235 mm

Application

- Check-in
- Repair and maintenance
- Wheel alignment
- Testing

Description:

Posts:

- Integrated eccentric brake system
- Emergency stop valve
- Obstruction system
- Pneumatic parking system in height adjustable ratchets
- Pump unit with immersed motor and control unit on front left post
- Pushbutton control unit with alarm signal
- Hydraulic cylinder under left platform
- Lifting and lowering by means of cables
- Emergency lowering valve

Platforms:

- One movable platform as standard
- Platforms prepared for AUTOPSTENHOJ scissor jack

Standard colours:

- Platforms & posts: RAL 7016 – grey
- Ramps: RAL 3020 – red

Versions:

- Available with different voltages
- Drive-on ramps and stops for surface-mounting, alternatively drive-over ramps for recessed installation
- S = flush platforms
- WL = with adjustable front recesses for turn tables and adjustable rear side slip plates supported by balls, center cover plate between recesses and side slip plates
- G = galvanized platforms
- 48 = 4800 mm platforms
- 51 = 5,100 mm platforms

Optional extras:

- Set of expansion bolts
- Extra control unit
- LED-lighting set
- Set of two 385 mm ramp extensions
- Set of two platform extensions (0.5 m)
- Pneumatic lock cylinder kit for slip plates

Special colours available on request!

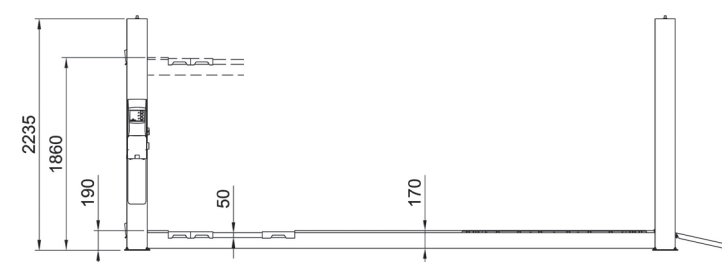
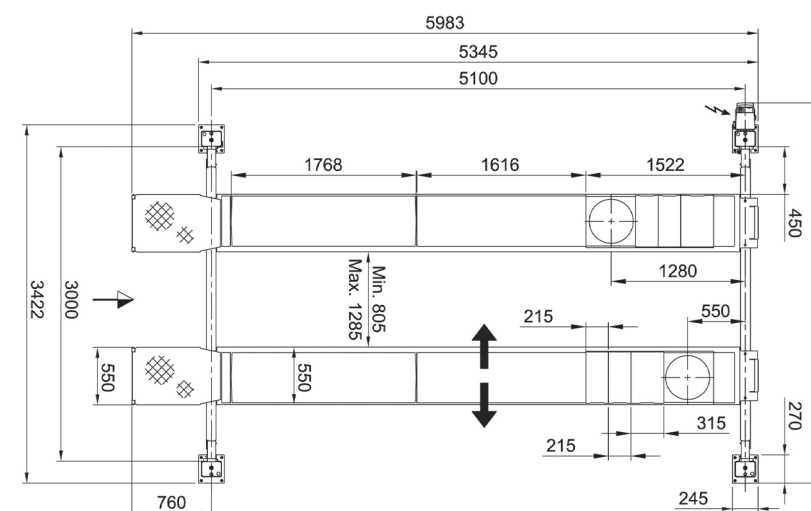

Ratchet for parking position



Pump and control unit on front left post

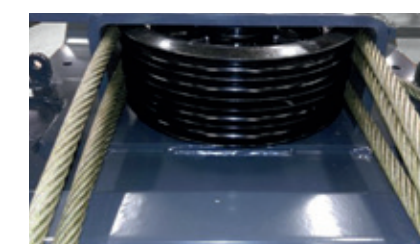

Pulley with steel cable

Major 5030-53 Combi

Electro-hydraulic 4-post lift, 5 t capacity, integrated free-wheel lift

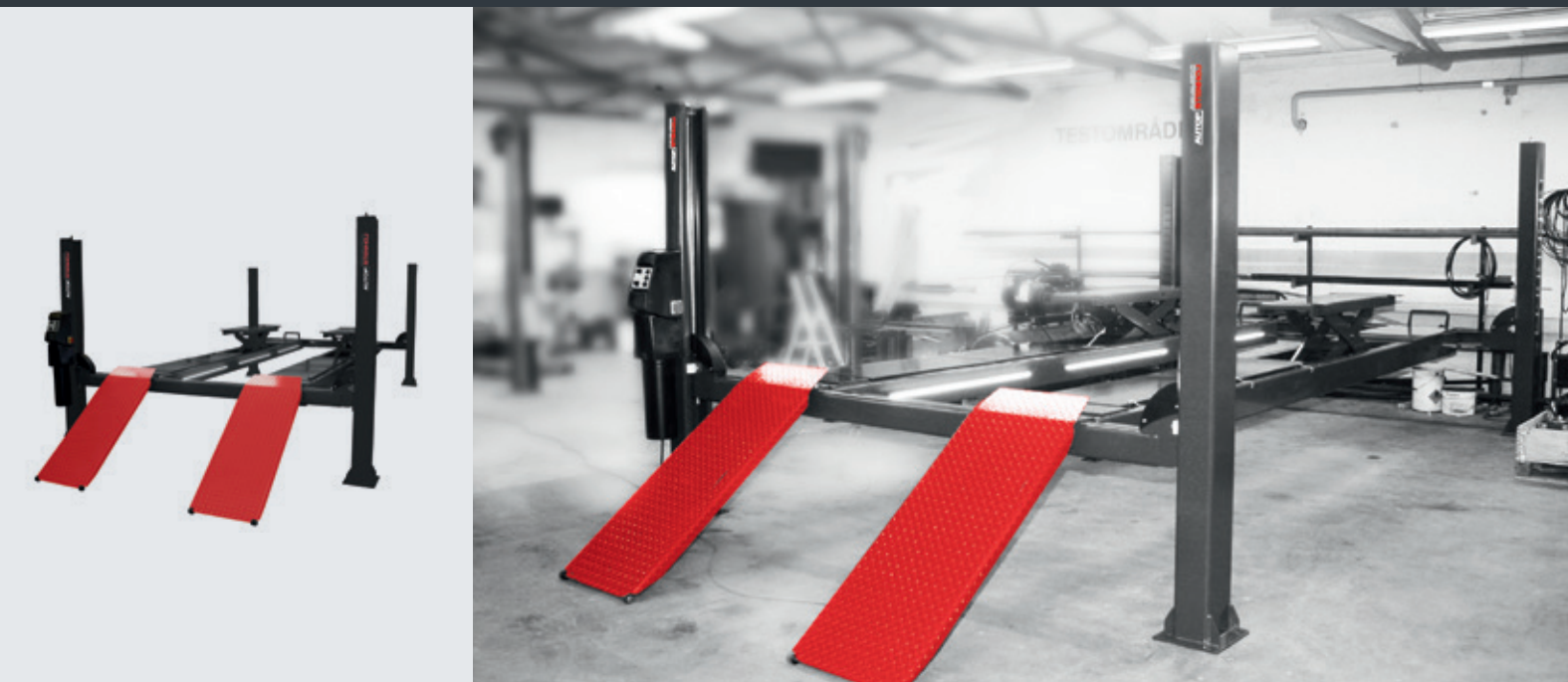

Technical data	
Lifting capacity	5,000 kg
Lifting height	1,670 mm
Working height	1,878 mm
Lifting / lowering time	approx. 33/24 sec.
Pump unit	3 kW
Voltage	3x230/400V – 50 Hz – 25 / 16 A

Free-wheel lift	
Lifting capacity	3,500 kg
Height	425 mm
Min. height (mm)	0
Length min. - max.	1,450 - 2,200 mm
Lifting / lowering time	hydraulic
Operation	9/12 sec.

Platforms	
Total length	6,810 mm
Usable length of platform	5,290 mm
Wheel base, min. - max.	variable
Platform width	560 mm
Distance between platforms	935 – 985 mm
Min. height	200/208 mm
Width between posts	3,000 mm
Total width - outer edges base plates	3,432 mm
Total height	2,233 mm

Application

- Check-in
- Repair and maintenance
- Wheel alignment
- Testing

Description:

Post:

- Integrated eccentric brake system
- Emergency stop valve
- Obstruction system
- Pneumatic parking system in height adjustable ratchets
- Pump unit with immersed motor and control unit on rear left post
- Pushbutton control unit with alarm signal
- Hydraulic cylinder under left platform
- Lifting and lowering by means of cables
- Emergency lowering valve

Platforms:

- Platform fixed
- Free-wheel lift integrated in platform

Standard colours:

- Platforms & posts: RAL 7016 – grey
- Ramps: RAL 3020 – red

Versions:

- Available with different voltages
- Drive-on ramps and stops for surface-mounting, alternatively drive-over ramps for recessed installation
- S = flush platforms
- W = with front recesses for turn tables and rear side slip plates
- 53 = 5,300 mm platforms

Optional extras:

- Set of expansion bolts
- LED-lighting set

Special colours available on request!

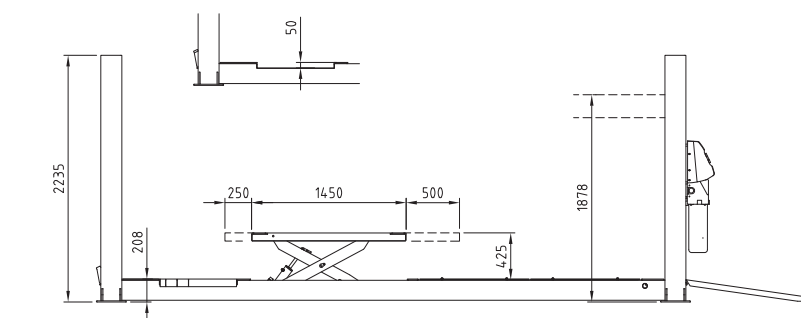

Ratchet for parking position

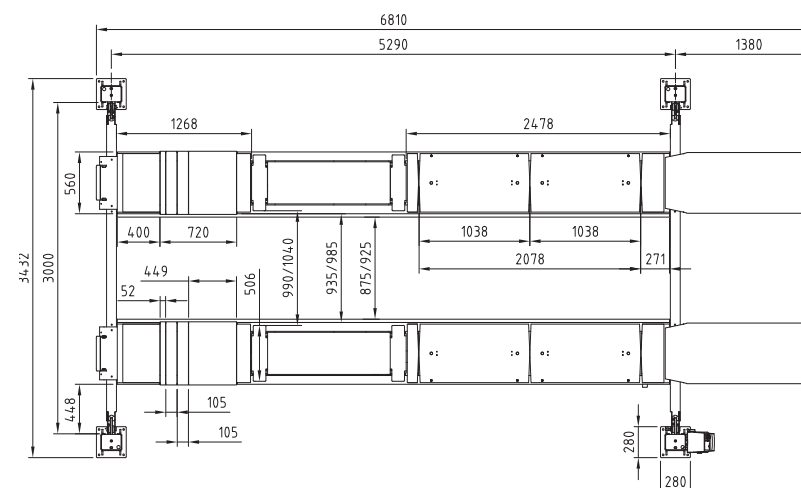

Control unit and power pack on rear left post

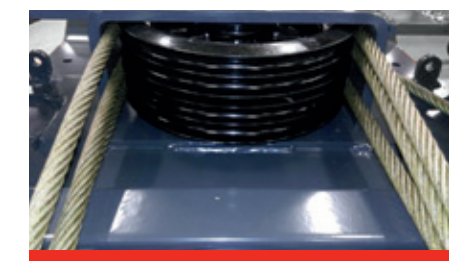

Pulley with steel cable

Major 5230

Electro-hydraulic 4-post lift, 5.2 t capacity

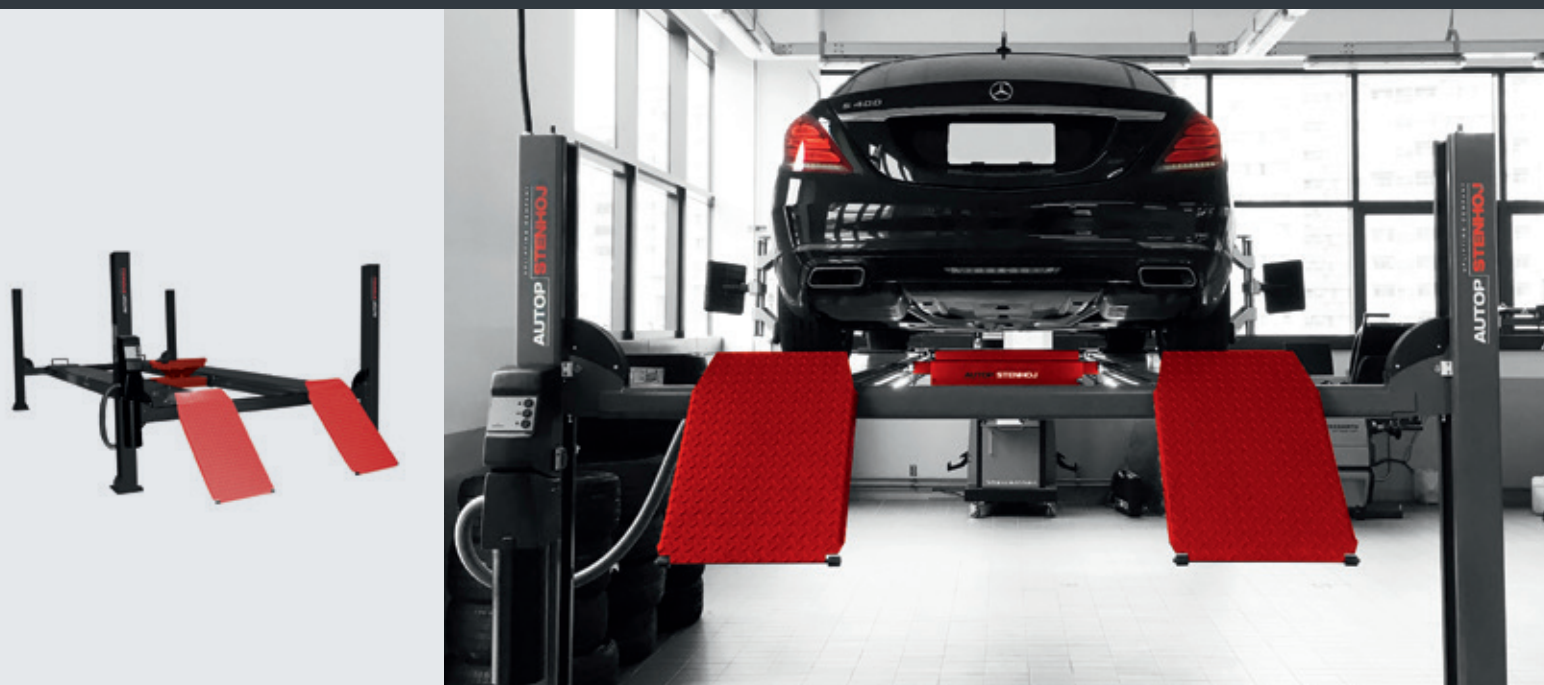

Technical data	
Lifting capacity	5,200 kg
Lifting height	1,670 mm
Working height	1,860 mm
Lifting / lowering time	Standard: 32 / 26 sec. D: 16 / 26 sec.
Pump unit	Standard: 3 kW D: 2 x 3 kW
Voltage	3x230 / 400V – 50 Hz – 25 / 16 A

Platforms	
Total length	5,560 / 5,980 / 6,780 mm
Usable length of platform	4,680 / 5,100 / 5,500 mm
Wheel base, min. - max.	variable
Platform width	550 mm
Models: 5230-47 and 5230-51	630 mm
Model: 5230-55	
Distance between platforms	725 - 1,210 mm
Min. height	140 / 170 / 160 / 190 mm
Width between posts	3,000 mm
Total width - outer edges base plates	3,422 mm
Total height	2,233 mm

Also available as inspection lifts:

As standard equipped with re-inforced posts and larger cable diameter for intensive usage in inspection centres. As standard delivered with:

P = play detector (pneumatically operated for both lateral and rotational movement, for axle load up to 3 t), operation with wireless hand lamp

Option:

D = double pump unit for quicker lifting time. Control unit on front left post

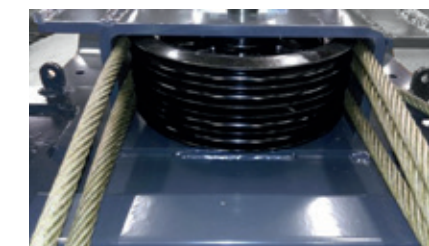
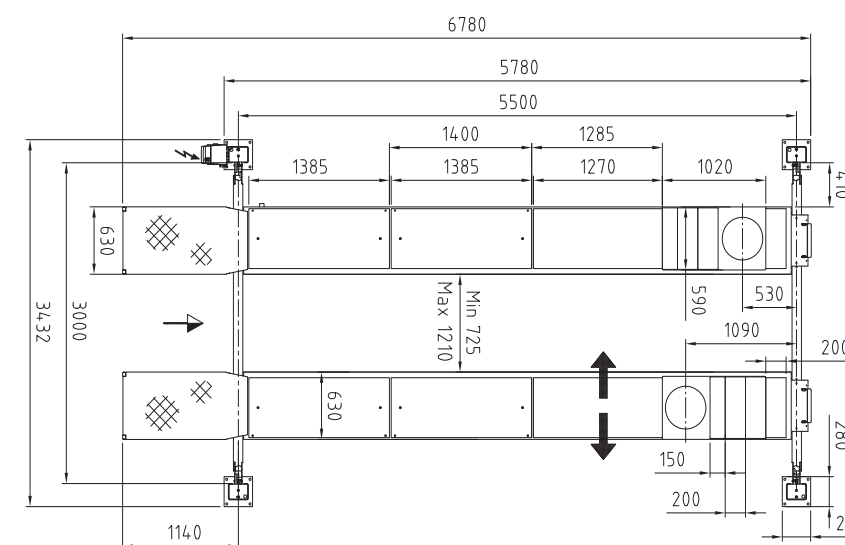

Pulley with steel cable



Ratchet for parking position



Control unit and power pack on rear left post

Application

- Check-in
- Repair and maintenance
- Wheel alignment
- Testing

Approvals / recommendations

- Renault

Description:

Posts:

- Integrated eccentric brake system
- Emergency stop valve
- Obstruction system
- Pneumatic parking system in height adjustable ratchets
- Pump unit with immersed motor and control unit on rear left post
- Pushbutton control unit with alarm signal
- Hydraulic cylinder under left platform
- Lifting and lowering by means of cables
- Emergency lowering valve

Platforms:

- One movable platform as standard
- Platforms prepared for AUTOPSTENHOJ scissor jack

Standard colours:

- Platforms & posts: RAL 7016 – grey
- Ramps: RAL 3020 – red

Versions:

- Available with different voltages
- Drive-on ramps and stops for surface-mounting, alternatively drive-over ramps for recessed installation
- S = flush platforms
- WL = with front recesses for turn tables and rear side slip plates, center cover plate between recesses and side slip plates
- G = galvanized platforms
- 42 = 4,200 mm platforms
- 47 = 4,700 mm platforms
- 51 = 5,100 mm platforms
- 55 = 5,500 mm platforms

Optional extras:

- Set of expansion bolts
- Extra control unit
- LED-lighting set
- Set of two cover plates for recesses
- Set of two 385 mm ramp extensions
- Set of two platform extensions (0.5 m)

Special colours available on request!

Major 2.0 5531

Electro-hydraulic 4-post lift, 5.5 t capacity



Technical data	
Lifting capacity	5,500 kg
Lifting height	1,670 mm
Working height	1,890 mm
Lifting / lowering time	Standard: 32 / 26 sec.
Pump unit	Standard: 3 kW
Voltage	3x230/400V – 50 Hz – 25 / 16 A

Platforms	
Total length	55: 6,765 mm
Usable length of platform	55: 5,500 mm
Wheel base, min. - max.	51 S: max. 5,000 mm 51 WL: min. 1,800 mm, max. 4,500 mm
Platform width	630 mm
Distance between platforms	775 – 1,270 mm
Min. height	230 mm
Width between posts	3,100 mm
Total width - outer edges base plates	3,532 mm
Total height	2,235 mm



Application

- Check-in
- Repair and maintenance
- Wheel alignment
- Testing

Description:

Posts:

- Integrated eccentric brake system
- Emergency stop valve
- Obstruction system
- Pneumatic parking system in height adjustable ratchets
- Pump unit with immersed motor and control unit on front left post
- Pushbutton control unit with alarm signal
- Hydraulic cylinder under left platform
- Lifting and lowering by means of cables
- Emergency lowering valve

Platforms:

- One movable platform as standard
- Platforms prepared for AUTOPSTENHOJ scissor jack

Standard colours:

- Platforms & posts: RAL 7016 – grey
- Ramps: RAL 3020 – red

Versions:

- Available with different voltages
- Drive-on ramps and stops for surface-mounting, alternatively drive-over ramps for recessed installation
- S = flush platforms
- WL = with adjustable front recesses for turn tables and adjustable rear side slip plates supported by balls, center cover plate between recesses and side slip plates
- G = galvanized platforms
- 55 = 5500 mm platforms

Optional extras:

- Set of expansion bolts
- Extra control unit
- LED-lighting set
- Set of two 385 mm ramp extensions
- Set of two platform extensions (0.5 m)
- Pneumatic lock cylinder kit for slip plates

Special colours available on request!

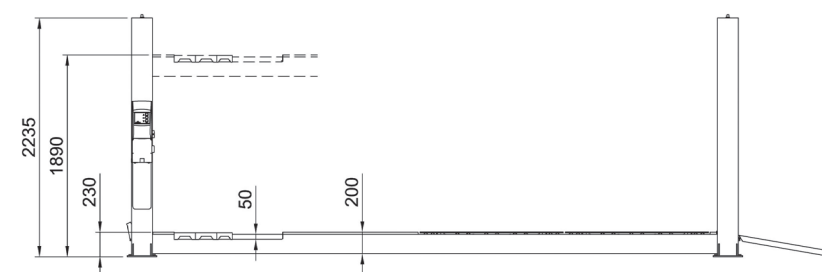
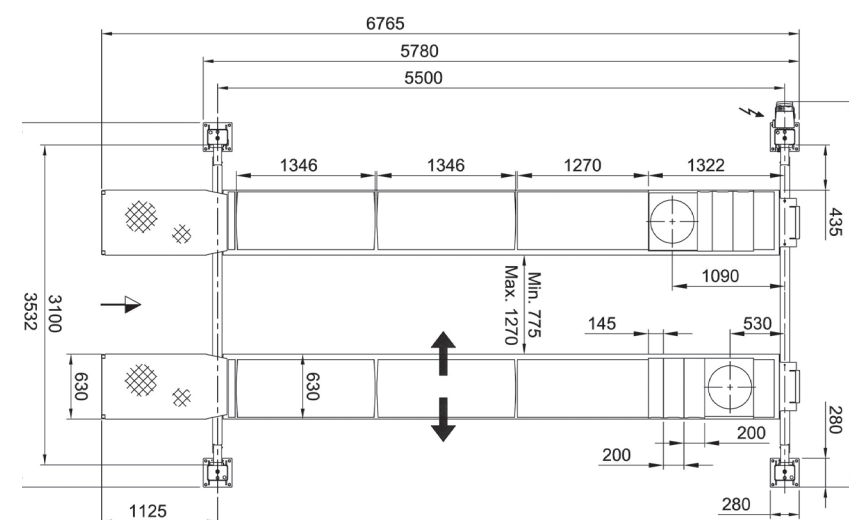

Ratchet for parking position



Pump and control unit on front left post

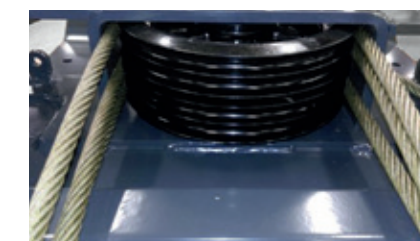

Pulley with steel cable

Major 5529-55 WL

Electro-hydraulic 4-post lift, 5.5 t capacity



Technical data	
Lifting capacity	5,500 kg
Stroke length	1,690 mm
Working height	1,920 mm
Lifting / lowering time	40 / 58 sec.
Pump unit	3 kW
Voltage	3x230 / 400V – 50 Hz – 16 A inert

Platforms	
Total length	7,455 mm
Usable length of platform	5,500 mm
Wheel base, min. - max.	variable
Platform width	650 mm
Distance between platforms	900 mm
Drive-on height	230 mm
Width between posts	2,900 mm
Total width - outer edges base plates	3,332 mm
Total height	2,235 mm



Application

- Check-in
- Repair and maintenance
- Wheel alignment
- Testing

Description:

Posts:

- Integrated eccentric brake system
- Emergency stop valve
- Obstruction system
- Pneumatic parking system in height adjustable ratchets
- Pump unit with immersed motor and control unit on rear left post
- Pushbutton control unit with alarm signal
- Hydraulic cylinder under left platform
- Lifting and lowering by means of cables
- Emergency lowering valve

Platforms:

- One moveable platforms as standard
- Platforms with tolerances of only max ± 1.0 mm length- and crosswise and ± 0.5 mm from left to right
- Distance pieces covering the entire length, fixated by steel edges in sides
- Platforms prepared for AUTOPSTENHOJ scissor jack with innovative air supply
- Platforms on stable cross beams

Standard colours:

- Spray-galvanized functional surfaces; platforms and posts: RAL 7016 – grey
- Ramps: RAL 3020 – red

Versions:

- Available with different voltages
- Drive-on ramps and stops for surface-mounting, alternatively drive-over ramps for recessed installation
- WL = with front and rear recesses for turn tables. Side slip plates available as optional extra.
- 55 = 5,500 mm platforms

Optional extras:

- Set of expansion bolts
- Extra control unit
- LED-lighting set
- Zinc coating of platforms

Special colours available on request!

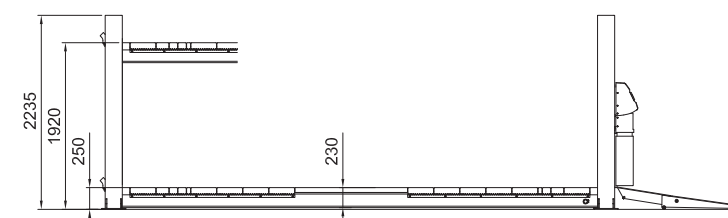
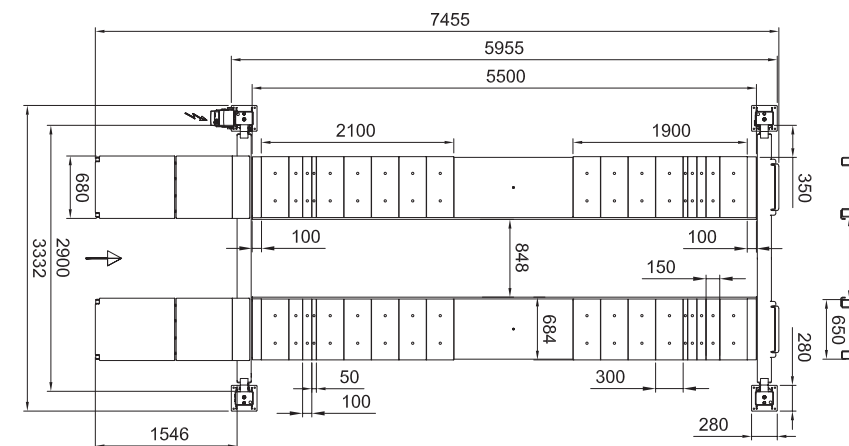

Slip plate



Ratchet for parking position



Control unit and power pack on rear left post

Major 6230

Electro-hydraulic 4-post lift, 6.2 t capacity



Technical data	
Lifting capacity	6,200 kg
Lifting height	1,670 mm
Working height	1,840 mm
Lifting / lowering time	approx. 48/58 sec.
Pump unit	3 kW
Voltage	3x230/400V – 50 Hz – 25 / 16 A

Platforms	
Total length	6,780 / 7,280 mm
Usable length of platform	5,500 / 6,000 mm
Wheel base, min. - max.	variable
Platform width	630 mm
Distance between platforms	725 – 1,210 mm
Min. height	170 mm
Width between posts	3,000 mm
Total width - outer edges base plates	3,432 mm
Total height	2,235 mm

Application

- Check-in
- Repair and maintenance

Approvals / recommendations

- Renault

Description:

Posts:

- Integrated eccentric brake system
- Emergency stop valve
- Obstruction system
- Pneumatic parking system in height adjustable ratchets
- Pump unit with immersed motor and control unit on rear left post
- Pushbutton control unit with alarm signal
- Hydraulic cylinder under left platform
- Lifting and lowering by means of cables
- Emergency lowering valve

Platforms:

- One movable platform as standard
- Platforms prepared for AUTOPSTENHOJ scissor jack

Standard colours:

- Platforms & posts: RAL 7016 – grey
- Ramps: RAL 3020 – red

Versions:

- Available with different voltages
- Drive-on ramps and stops for surface-mounting, alternatively drive-over ramps for recessed installation
- S = flush platforms
- G = galvanized platforms
- 55 = 5,500 mm platforms
- 60 = 6,000 mm platforms

Optional extras:

- Set of expansion bolts
- Extra control unit
- LED-lighting set
- Set of two 385 mm ramp extensions
- Set of two platform extensions (0.5 m)

Special colours available on request!

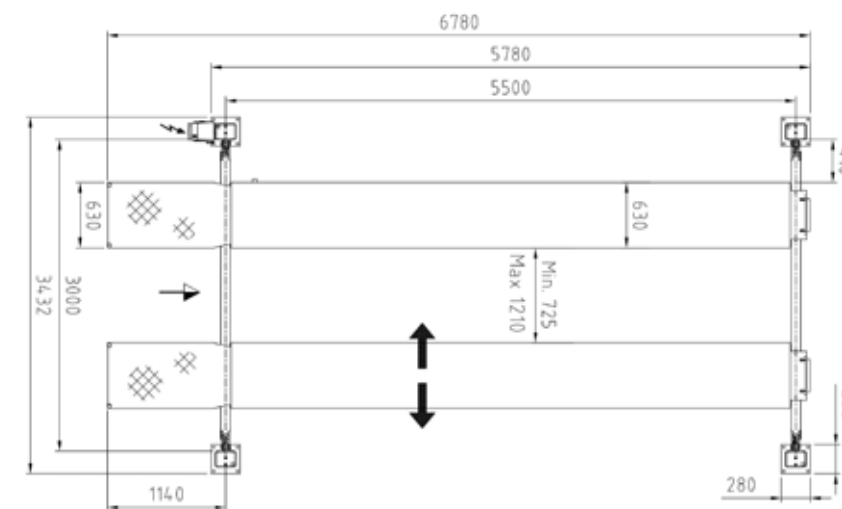

Ratchet for parking position



Control unit and power pack on rear left post

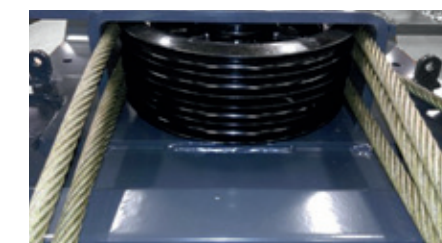

Pulley with steel cable

Major 7230

Electro-hydraulic 4-post lift, 7.2 t capacity



Technical data	
Lifting capacity	7,200 kg
Lifting height	1,670 mm
Working height	1,840 mm
Lifting / lowering time	approx. 40/58 sec.
Pump unit	3 kW
Voltage	3x230/400V – 50 Hz – 25/16 A

Platforms	
Total length	7,280 mm
Usable length of platform	6,000 mm
Wheel base, min. - max.	variable
Platform width	630 mm
Distance between platforms	725 – 1,210 mm
Min. height	170 mm
Width between posts	3,000 mm
Total width - outer edges base plates	3,432 mm
Total height	2,235 mm

Application

- Direktannahme
- Repair and maintenance

Approvals / recommendations

- Renault

Description:

Post:

- Integrated eccentric brake system
- Emergency stop valve
- Obstruction system
- Pneumatic parking system in height adjustable ratchets
- Pump unit with immersed motor and control unit on rear left post
- Pushbutton control unit with alarm signal
- Hydraulic cylinder under left platform
- Lifting and lowering by means of cables
- Emergency lowering valve

Platforms:

- One movable platform as standard
- Platforms prepared for AUTOPSTENHOJ scissor jack

Standard colours:

- Platforms & posts: RAL 7016 – grey
- Ramps: RAL 3020 – red

Versions:

- Available with different voltages
- Drive-on ramps and stops for surface-mounting, alternatively drive-over ramps for recessed installation
- S = flush platforms
- G = galvanized platforms

Optional extras:

- Set of expansion bolts
- Extra control unit
- LED-lighting set
- Set of two 385 mm ramp extensions
- Set of two platform extensions (0.5 m)

Special colours available on request!

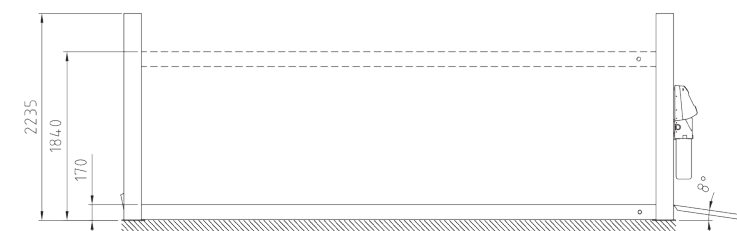
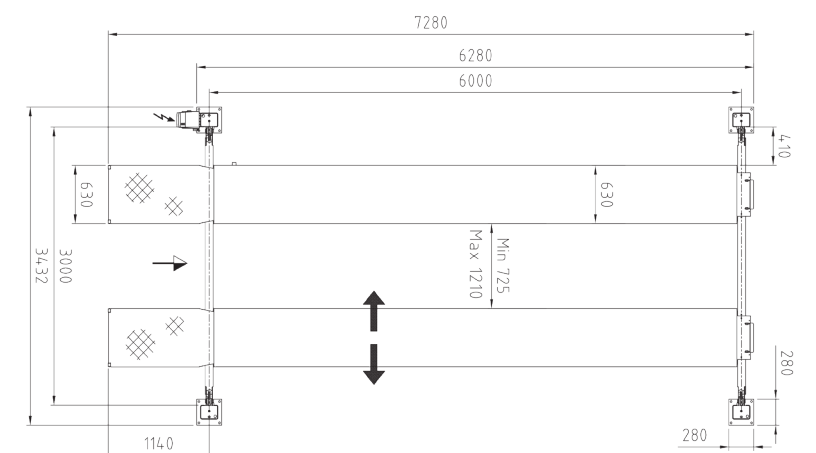

Ratchet for parking position



Control unit and power pack on rear left post



Pulley with steel cable

Major 4000–6000 MOT/ATL

Electro-hydraulic 4-post lift, 4.0, 4.8, 5.2 & 6.5 t capacity

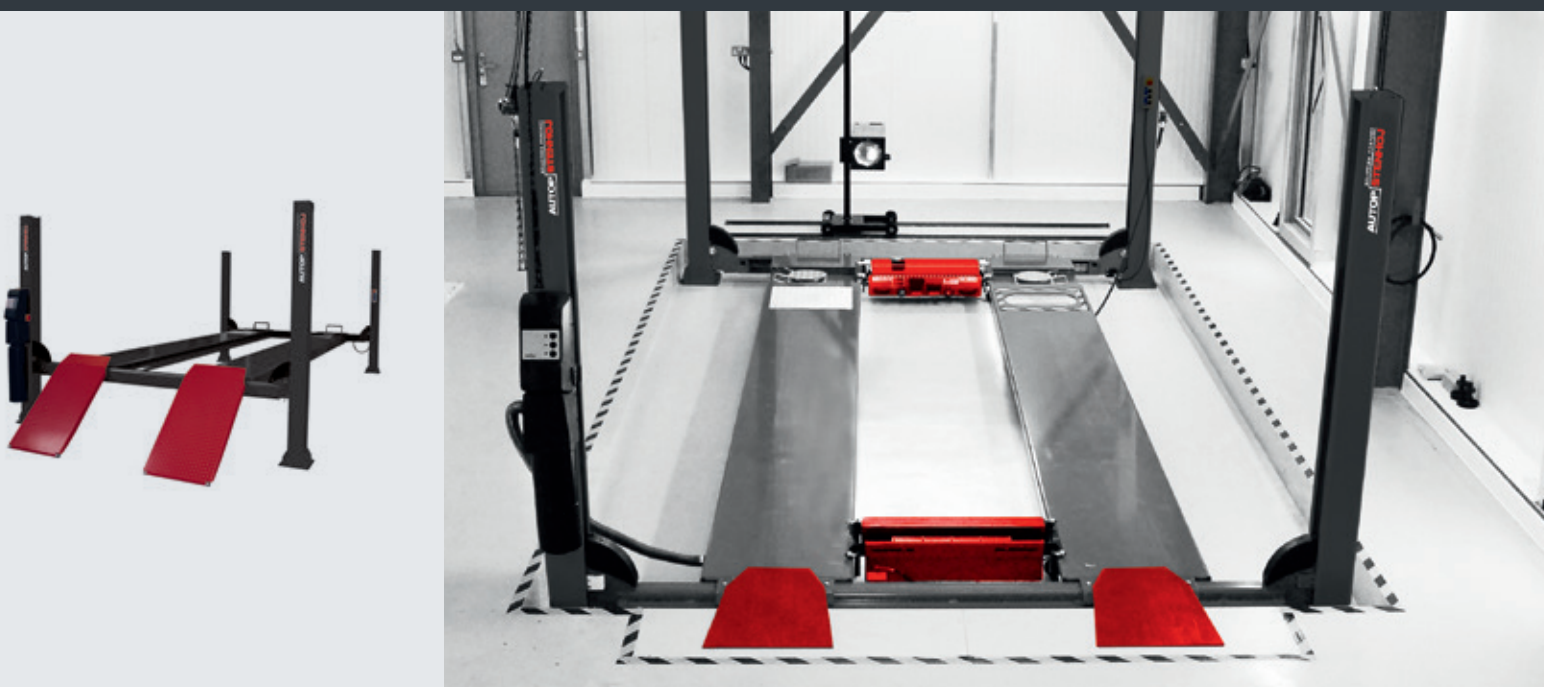

Technical data	
Lifting capacity, bis	6,500 kg
Lifting height	1,670 mm
Working height	1,810 – 1,840 mm
Lifting / lowering time	4 t = 24 / 26 sec. 4.8 & 5.2 t = 32 / 26 sec. 6.5 t = 40 / 58 sec.
Pump unit	3 kW
Voltage	400/3/50 – 240/1/50

* Dimension sketches to be found on our website.

Optional extras:

- Set expansion bolts
- LED-lighting set
- Set of two cover plates for recesses
- Set of two 385 mm ramp extensions
- Set of two platform extensions (0.5 m)
- Set of two cover plates

Application

- Check-in
- Repair and maintenance
- Testing

Description:

- Integrated eccentric brake system
- Emergency stop valve
- Obstruction system
- Pneumatic parking system in height adjustable ratchets
- Pump unit with immersed motor and control unit on rear left post; delivered with extra control unit for front right post
- Pushbutton control unit with alarm signal
- Hydraulic cylinder under left platform
- Lifting and lowering by means of cables
- Emergency lowering valve
- Both platforms fixed
- Platforms prepared for AUTOPSTENHOJ scissor jack

Standard colours:

- Platforms & Posts: RAL 7016 – grey
- Ramps: RAL 3020 – red

Versions:

- Available with different voltages
- Available with different platform lengths

Special colours available on request!

MOT Lifts:

Worldwide accepted inspection lifts which have been specified and constructed according to UK MOT requirements. MOT lifts are as standard delivered with front recesses with turntables and extra control unit for operation from front right post. Drive-on ramps and stops for surface-mounting, alternatively drive-over ramps for recessed installation.

ATL Lifts:

Worldwide accepted inspection lifts which have been specified and constructed according to UK MOT and ATL (automated test lanes VOSA) requirements. ATL lifts are as standard delivered with front recesses with turntables and extra control unit for operation from front right post; ATL lifts are furthermore equipped with re-inforced posts and larger cable diameter and a play detector (pneumatically operated for both lateral and rotational movement, for axle load up to 3 t), operation with wireless hand lamp. Drive-on ramps and stops for surface-mounting, alternatively drive-over ramps for recessed installation

WL = with front recesses for turn tables and rear side slip plates, center cover plate between recesses and side slip plates

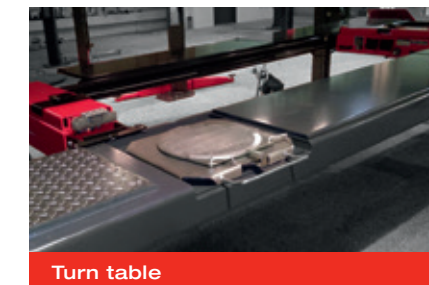

Turn table



Wireless hand lamp for play detector



Ratchet for parking position

Micro 20 & 26 & 40 air-hydraulic

Air-hydraulic scissor jack, 2/2.6/4 t capacity

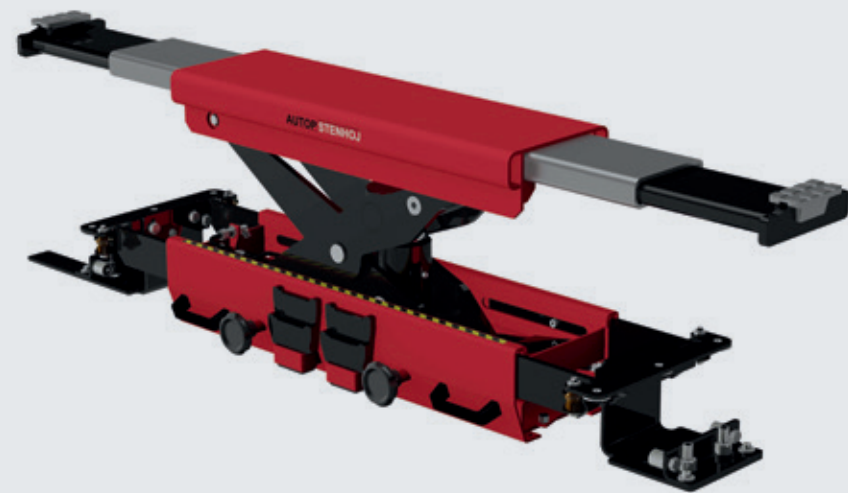

Technical data	
Lifting capacity	2,000 / 2,600 / 4,000 kg
Lifting height	300 / 250 mm
Min. height	75 mm
Lifting / lowering time	27/5 / 23/5 / 60/5 sec.
Operation	air-hydraulic
Pressure min. - max.	5.5/8 / 8.5/12 bar
Extension	792 - 1,600 mm / 792 - 1,460 mm / 780 - 1,500 mm

Application

- For use on Major platform lifts

Approvals / recommendations

- Micro 20:
Volvo

Description:

Micro 20 & 26:

- Double-acting cylinder
- 2-hand operation
- Mechanical parking system
- Non-return valve
- Retaining device
- Double arm extension
- Galvanized arms

Micro 40:

- 2-hand operation
- Deadman control
- Pressure relief valve
- Retaining device
- Double arm extension

Standard colours:

- RAL 3020 - red

Versions:

- Micro 20 = 2,000 kg & 1,600 mm extension
- Micro 26 = 2,600 kg & 1,460 mm extension
- Special version Micro 26 = 2,600 kg & 1,600 mm extension
- Micro 40 = 4,000 kg & 1,500 mm extension
- Delivery includes a variety of pads

Optional extras:

- Air connection kits
- A large program of extra pads

Special colours available on request!

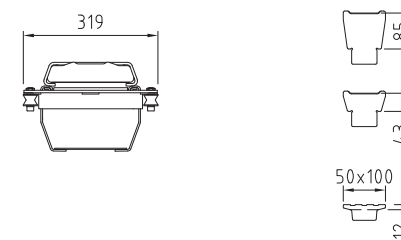
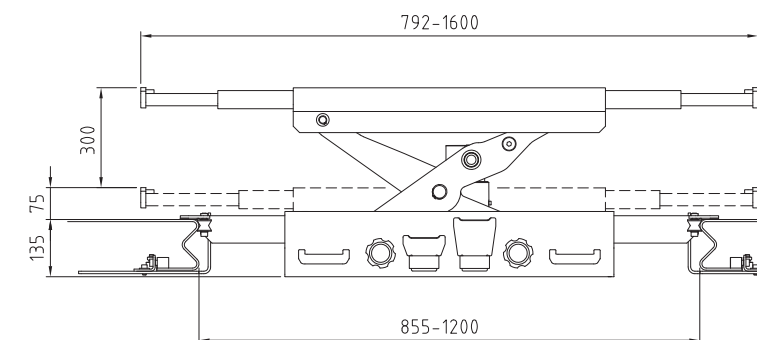

Air-hydraulic Micro 26 on BL 2.65 F550



Air-hydraulic Micro 26 on PL 2.40 F



We offer a large program of extra pads for the Micro jacks

Micro 20 & 26 full-hydraulic

Full-hydraulic scissor jacks, 2 & 2.6 capacity



Technical data	
Lifting capacity	2,000 / 2,600 kg
Lifting height	250 mm
Min. height	75 mm
Lifting / lowering time	5 / 15 sec.
Operation	full-hydraulic
Pressure	230 bar
Extension	Micro 26: 792 - 1,460 mm Micro 20: 792 - 1,600 mm

Application

- For use on Major platform lifts

Description:

- Operates on the Major lift pump
- 2-hand operation
- Mechanical parking system
- Non-return valve
- Double arm extension
- Galvanized arms

Standard colours:

- RAL 3020 - red

Versions:

- Micro 20 = 2,000 kg & 1,600 mm extension
- Micro 26 = 2,600 kg & 1,460 mm extension
- Special version Micro 26 = 2,600 kg & 1,600 mm extension
- Delivery includes a variety of pads

Optional extras:

- Hydraulic connection kits
- A large program of extra pads

Special colours available on request!

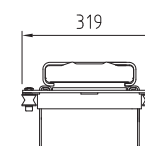
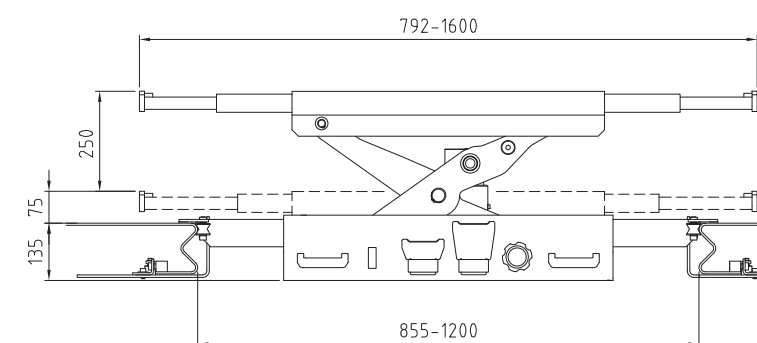

We offer a large program of extra pads for the Micro jacks



Micro Full hydraulic

MagiX 30

Electro-hydraulic scissor lift, 3 t capacity



Technical data	
Lifting capacity	3,000 kg
Lifting height	1,845 mm
Working height	S: 1,950 mm I: 1,845 mm + Rubber pads
Lifting / lowering time	45 (40) sec.
Pump unit	2.2 kW
Voltage	3x230 / 400V – 50 Hz

Scissor platforms	
Platform length	1,490 – 2,040 mm
Platform width	670 mm
Distance between platforms	720 mm
Min. height	105 mm
Depth of recess	S: 0 mm I: 105 mm

Application

- Check-in
- Repair and maintenance

Approvals / recommendations

- Renault
- Volvo

Description:

- Double master / slave system
- Control stand with integrated pump unit and alarm signal
- Electronic synchronization
- Emergency lowering valve
- Sturdy scissor construction
- No mechanical connection between scissor sections
- Optimum access to vehicle
- Low minimum height

Standard colours:

- Platforms & scissor: RAL 7016 – grey
- Ramps: RAL 3020 – red

Versions:

- Available with different voltages
- For surface-mounting or recession
- S = superstructure on floor
- I = superstructure in floor
- G = galvanized upper plates and base frame

Optional extras:

- LED-lighting set for surface-mounted versions
- Set of expansion bolts
- Set rubber blocks, 40, 60, 70, 80 and 100 mm

Special colours available on request!

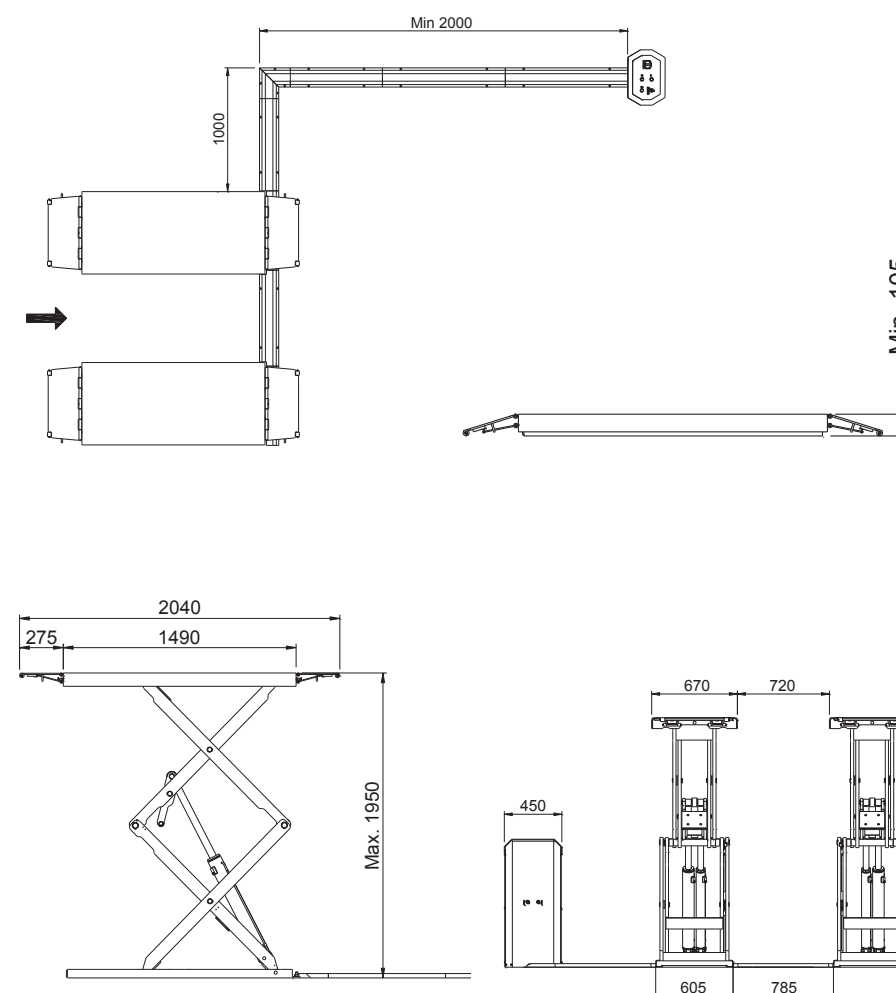

Recessed installation



Available with galvanized base frame



Self-lubricating bearing

MagiX 35 LSMG II

Electro-hydraulic mobile short-rise scissor lift, 3.5 t capacity



Product similar to illustration

Technical data	
Lifting capacity	3,500 kg
Lifting height	895 mm
Working height	1,000 mm + Rubber pads
Lifting / lowering time	16 sec.
Pump unit	2.2 kW
Voltage	3Ph - 230/400V – 50 / 60 Hz

Scissor platforms	
Platform length	1,400 – 1,974 mm
Platform width	480 mm
Distance between platforms	1,000 mm
Min. height	105 mm
Depth of recess	0 mm

Application

- Repair and maintenance
- Tyre change

Description:

- Double hydraulic system with 2 cylinders under each scissor section, therefore no compressed air and no safety ratchet necessary
- Leverage of full capacity 3.5 t from the lowest position
- Mechanic synchronization through cross-bars
- Emergency lowering valves can manually be opened
- Sturdy scissor construction for high directional stability
- Ramps and platforms made of tear plates, for easy drive-on, also with wet wheels
- Base frames, platforms and ramps galvanized as standard
- Increased stability by roller guides under the platform
- Mobile-kit in standard scope of delivery, consisting of: rollers and lever for moving of the scissor lift
- Rubber blocks 1 set = 4 pcs, H=40 mm included in scope of delivery

Standard colours:

- Platforms & ramps: galvanized
- Scissors: RAL 7016 – grey

Versions:

- Available with different voltages

Optional extras:

- Set of expansion bolts
- Set rubber blocks, 20, 40, 60, 70, 80 and 100 mm

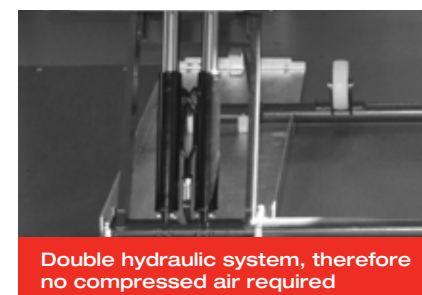
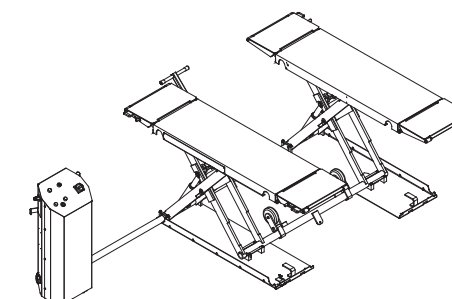
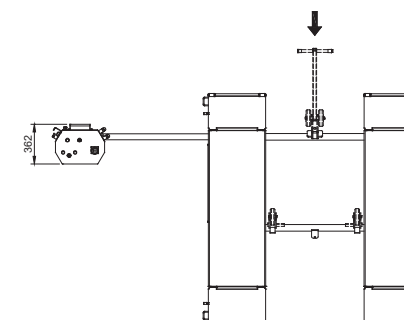
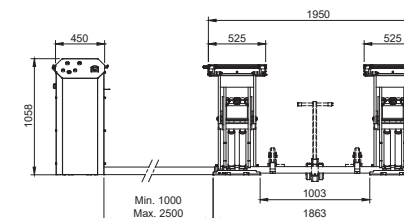
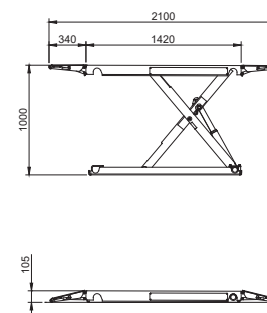

Double hydraulic system, therefore no compressed air required



Mobile-kit for moving the lift



Stable, galvanized ramps made of tear plate, for a better drive-on situation, even in damp conditions

MagiX 35 DS

Electro-hydraulic double scissor lift, 3.5 t capacity



Technical data	
Lifting capacity	3,500 kg
Lifting height	1,900 mm
Working height	2.000 mm / 1.900 mm + Rubber pads
Lifting / lowering time	40 / 38 sec.
Pump unit	2.2 kW
Voltage	3Ph - 230/400V - 50/60 Hz

Scissor platforms	
Platform length	1,480 – 2,200 mm
Platform width	625 mm
Distance between platforms	900 mm (recommended)
Max. distance scissor - control column	2 m
Min. height	Superstructure on floor: ≤ 100 mm Superstructure in floor: 0 mm
Depth of recess	Superstructure on floor: 0 mm Superstructure in floor: 105 mm

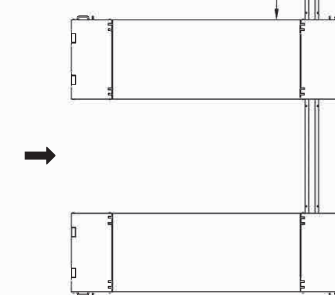
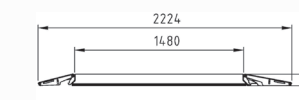
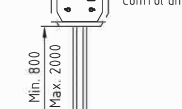
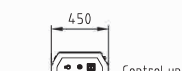
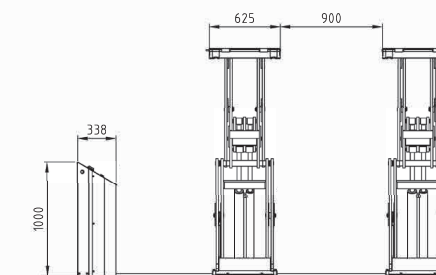
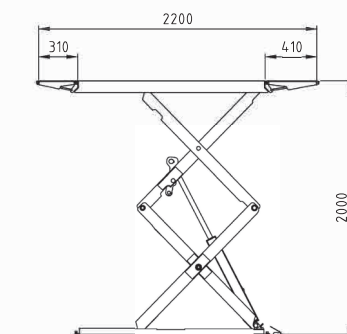

Base frame galvanized as standard



Lubrication free teflon sliding bearings in all joints



Special flat design ≤ 100 mm



Stable ramps made of tear plate, for a better drive-on situation, even in damp conditions

Application

- Check-in
- Repair and maintenance

Approvals / recommendations

- Volvo

Description:

- Double master / slave system, therefore no compressed air and no safety ratchet necessary
- Self-locking parachute valves in cylinders against sudden increase of speed
- Control column with push buttons, integrated pump unit and alarm signal
- Electronic synchronization through photo sensor and reflector, stops lift from 50 mm difference in height
- Emergency lowering valves can manually be opened
- Sturdy scissor construction for high directional stability
- Ramps made of tear plates, for easy drive-on, also with wet wheels
- Base frame galvanized as standard
- No mechanical connection between scissor sections, therefore free gangway
- Lubrication free teflon sliding bearings in all joints
- Optimum lifting area from small passenger car up to VW T6 short wheel base / BMW series 7 long (G12)
- Low minimum height ≤ 100 mm, for perfect drive-over situation, also for flat vehicles
- No fixed drive-on direction, lift is reversible, flexible positioning of control column.
Recommended: front left side
- Rubber blocks 1 set = 4 pcs, H=40 mm, as well as hose and cable covers included in scope of delivery

Standard colours:

- Platforms & scissor: RAL 7016 – grey
- Ramps: RAL 3020 – red

Versions:

- Available with different voltages
- For surface-mounting or recession, with the same lift version
- G = galvanized platforms

Optional extras:

- Set of expansion bolts
- LED-lighting set for surface-mounted installation
- Installation frame galvanized, for recessed installation
- Set rubber blocks, 20, 40, 60, 70, 80 and 100 mm
- Hose extensions incl. covers (+ 1 meter)
- Additional long drive-over ramps for lowered cars
- Cross bar for lifting 4x4 vehicles

Special colours available on request!

MagiX 45

Electro-hydraulic scissor lift with platforms, 4.5 t capacity



Technical data	
Lifting capacity	4,500 kg
Lifting height	1,900 mm (surface-mounted)
Working height	1,870 mm
Lifting / lowering time	55 sec.
Pump unit	4 kW
Voltage	3x230 / 400V – 50 Hz

Free-wheel lift	
Lifting capacity	4,000 kg
Lifting height	400 mm
Min. height	0 mm
Lifting / lowering time	7 / 15 sec.
Operation	hydraulic
Necessary air pressure	6 bar
Length	1,450 – 1,965 mm

Scissor platforms	
Platform length	4,500 / 4,800 / 5,200 mm
Platform width	660 mm
Distance between platforms	875 - 1,000 mm
Min. height	230 mm
Depth of recess	0 mm

Application

- Check-in
- Repair and maintenance
- Wheel alignment

Approvals / recommendations

- Renault
- MS 45 S-45 & MS 45 WL-45: Volvo

Description:

- Double master / slave system
- Control stand with integrated pump unit and alarm signal
- Electronic synchronization
- Emergency lowering valve
- Sturdy scissor construction
- No mechanical connection between scissor sections
- Optimum access to vehicle
- Low minimum height

Standard colours:

- Platforms and scissor: RAL 7016 - grey
- Ramps: RAL 3020 - red

Versions:

- Available with different voltages
- We recommend surface-mounted installation
- S = flush platforms, incl. guiding edges for scissor jack
- WL = with front recesses for turn tables and rear side slip plates, incl. guiding edges for scissor jack
- Combi = platforms with integrated free-wheel lift
- Also available with galvanized base frame and platforms
- 45 = 4,500 mm platforms
- 48 = 4,800 mm platforms
- 52 = 5,200 mm platforms
- Incl. drive-on ramps, stops and LED-lighting set

Optional extras:

- Set of expansion bolts
- Set rubber blocks, 40, 60, 70, 80 and 100 mm
- Guiding edges for scissor jack for Combi-versions
- Play detector

Special colours available on request!

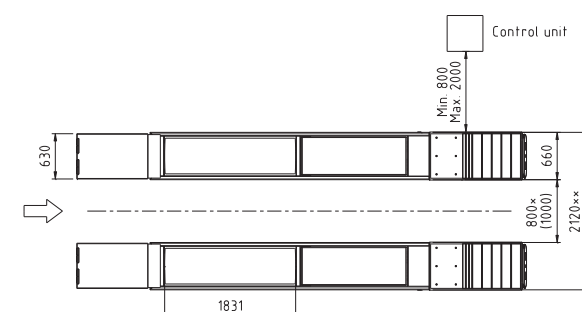
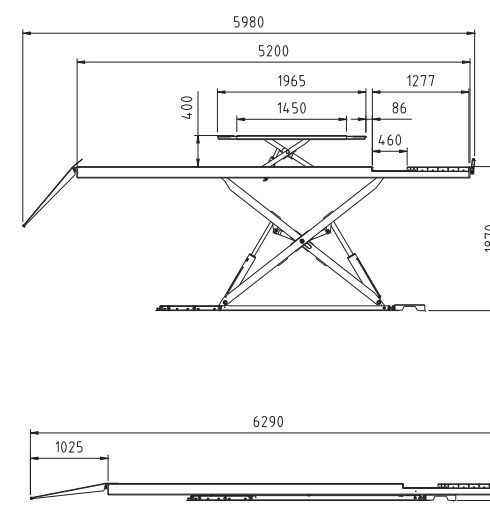

Control stand



Adjustable base frame



Infra-red sensor and fillers

MagiX 50

Electro-hydraulic scissor lift with platforms, 5 t capacity



Technical data	
Lifting capacity	5,000 kg
Lifting height	1,810 mm
Working height	1,810 mm
Lifting / lowering time	55 sec.
Pump unit	4 kW
Voltage	3x230 / 400V – 50 Hz

Free-wheel lift	
Lifting capacity	4,000 kg
Lifting height	400 mm
Min. height	0 mm
Lifting / lowering time	7 / 15 sec.
Operation	hydraulic
Necessary air pressure	6 bar
Length	1,450 – 1,965 mm

Scissor platforms	
Platform length	4,500 / 4,800 / 5,200 mm
Platform width	660 mm
Distance between platforms	800 – 1,000 mm
Min. height	0 mm
Depth of recess	340 mm

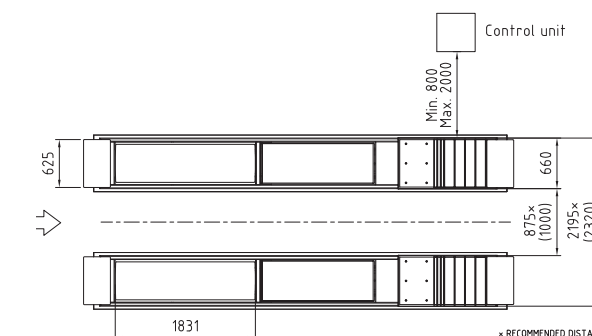

Application

- Check-in
- Repair and maintenance
- Wheel alignment

Approvals / recommendations

- Renault

Description:

- Double master / slave system
- Control stand with integrated pump unit and alarm signal
- Electronic synchronization
- Emergency lowering valve
- Sturdy scissor construction
- No mechanical connection between scissor sections
- Optimum access to vehicle
- Low minimum height

Standard colours:

- Platforms and scissors: RAL 7016 – grey
- Ramps: RAL 3020 – red

Versions:

- Available with different voltages
- We recommend recession in floor
- S = superstructure on floor
- I = I = superstructure in floor
- W = with front recesses for turn tables and rear side slip plates, incl. guiding edges for scissor jack

- Combi = platforms with integrated free-wheel lift
- Also available with galvanized base frame and platforms
- 45 = 4,500 mm Platforms
- 48 = 4,800 mm Platforms
- 52 = 5,200 mm Platforms
- Incl. drive-over ramps, stops and LED-lighting set

Optional extras:

- Set of expansion bolts
- Set rubber blocks, 40, 60, 70, 80 and 100 mm
- Guiding edges for scissor jack for Combi-versions
- Play detector

Special colours available on request!

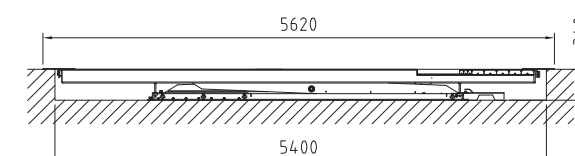
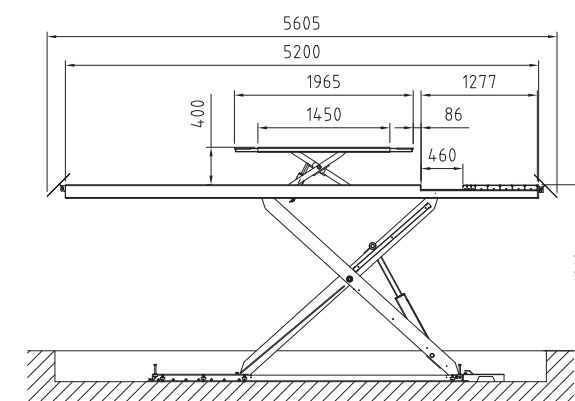

Control stand



Adjustable base frame



Infra-red sensor and fillers

Maxi 100

Electro-hydraulic 4-post lift, 10 t capacity



Technical data	
Lifting capacity	10,000 kg
Lifting height	1,700 mm
Stroke length	1,435 mm
Lifting / lowering time	45 sec.
Motor	3 kW
Operation	hydraulic
Voltage	3x230/400V-50 Hz – 25/16 A
Necessary air pressure min. / max.	7/10 bar

Platforms	
Min. height	265 mm
Drive-through width	2,054/2,364/2,773 mm
Width between posts	2,800/3,120/3,520 mm
Total width	3,490/3,810/4,210 mm
Total height	2,354 mm
Total length	5,900/6,400/8,300/8,800 mm
Platform length	4,600/7,000 mm
Utilization area of platform	variable
Platform width	650/750 mm
Distance between platforms	525/775 – 720/1,060 – 1,000/1,240 mm
Wheel base	variable

Application

- Repair and maintenance

Description:

- Friction brake system in the event of cable failure
- Pneumatic parking system in height adjustable ratchets
- Pump unit with immersed motor
- Pump and control unit on front left post
- Pushbutton control unit with alarm signal
- One movable platform as standard

Standard colours:

- Platforms & posts: RAL 7016 - grey
- Ramps: RAL 3020 - red

Versions:

- Available with different voltages
- 4,600 mm flush platforms, 7,000 mm flush platforms
- 1,100 or 1,600 mm drive-on ramps
- Drive-on ramps and stops for surface-mounting; alternatively drive-over ramps for recessed installation

Optional extras:

- Set of expansion bolts
- Lighting set
- Auxiliary jack
- 3rd platform

Special colours available on request!

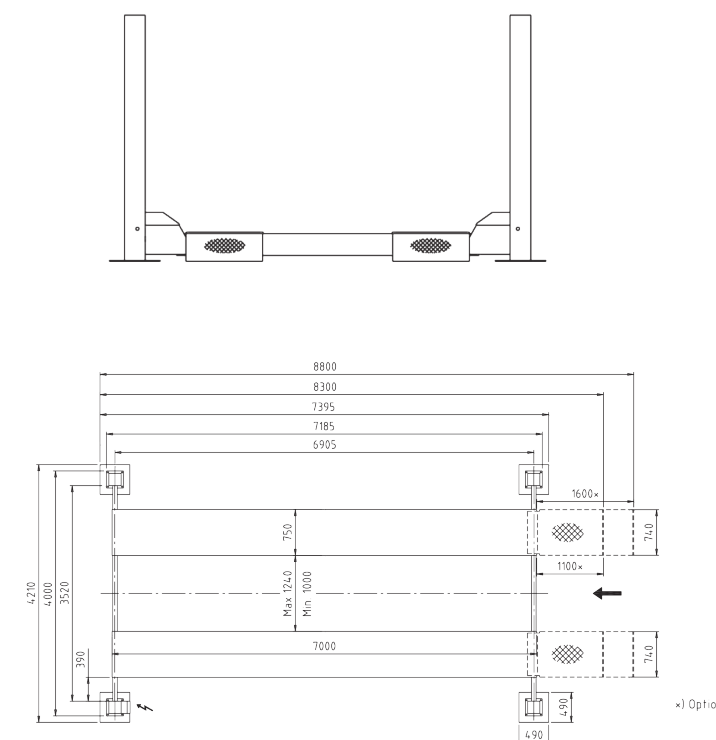

Ratchet parking system



Pump and control unit on front left post



Auxiliary jack and lighting set

Maxi 160, 200 & 240

Electro-mechanical 4-post lift, 16, 20 & 24 t capacity



Technical data	
Lifting capacity	16,000/20,000/24,000 kg
Lifting height	1,850 mm
Stroke length	1,545/1,555 mm
Lifting / lowering time	120 sec.
Pump unit	4 x 2.2/ 6 x 2.2 kW
Operation	mechanical
Voltage	3x230/400V-50 Hz – 35/45 A / 3x230/400V-50 Hz – 45/60 A

Platforms	
Min. height	295/305 mm
Drive-through width	3,200/3,470 mm
Width between posts	3,200/3,470 mm
Total width	3,920/4,190
Total height	2,550 mm
Total length	9,005/9,745/11,505/12,395 mm
Platform length	5,000/7,500/8,000/8,500/9,000 mm
Utilization area of platform	variable
Platform width	700 mm
Distance between platforms	950/1,180 mm
Wheel base	variable

Application

- Repair and maintenance

Description:

- Obstruction system
- Each post equipped with a motor and elastic coupling
- Self-carrying spindles with carrying and safety nuts
- Pushbutton control unit with alarm signal
- One movable platform as standard

Standard colours:

- Platforms & posts: RAL 7016 - grey
- Ramps: RAL 3020 - red

Versions:

- Available with different voltages
- Maxi 160 & 200:
 - 3,950 mm flush platforms
 - 7,500 mm flush platforms
 - 8,000 mm flush platforms
 - 8,500 mm flush platforms
 - 9,000 mm flush platforms
- Maxi 240:
 - 2 x 5,000 mm flush platforms
- 1,260, 2,000 or 2,800 mm drive-on ramps
- Drive-on ramps and stops for surface-mounting; alternatively drive-over ramps for recessed installation

Optional extras:

- Auxiliary jack
- Lighting set
- Scissor jack
- 3rd platform

Special colours available on request!

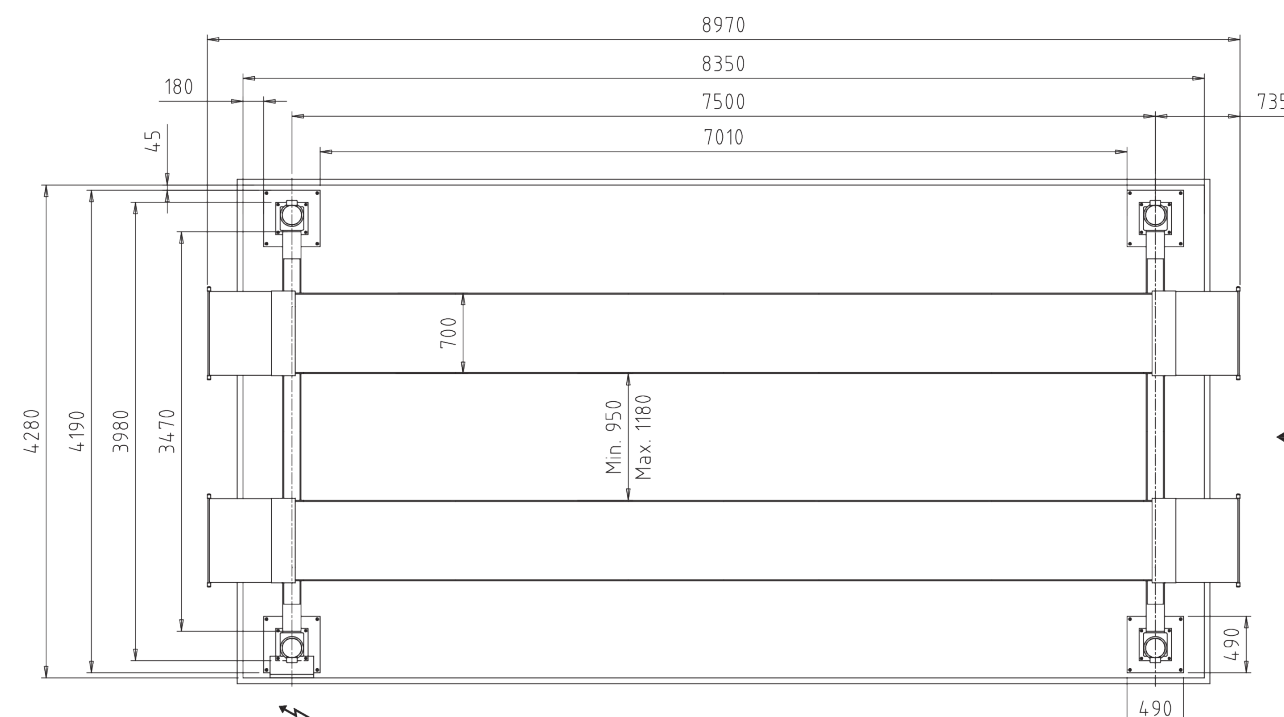

Micro 60 - 140

Air-hydraulic auxiliary jack with 1 or 2 cylinders, 6, 10, 12 & 14 t capacity



Technical data	
Lifting capacity	6,000 / 10,000 / 12,000 / 14,000 kg
Stroke length	200 mm
Operation	air-hydraulic
Pressure min. / max.	8-12 bar

Application

- For usage on Maxi-platform lifts

Description:

- Transversely sliding cylinders
- Rapid and precise air-hydraulic unit with highspeed approach control
- Control panel at ergonomical working height
- Deadman control
- Pressure relief valve

Standard colours:

- RAL 3020 - red
- RAL 7016 - grey

Versions:

- 1 or 2 cylinders with adjustable bridge: 590-890 mm or 850-1,150 mm
- 1-cylinders with 1 x 100 mm extension
- 2-cylinders with 2 x 100 mm extensions

Optional extras:

- Air connection kits
- Traverse
- Auxiliary bridge

Special colours available on request!

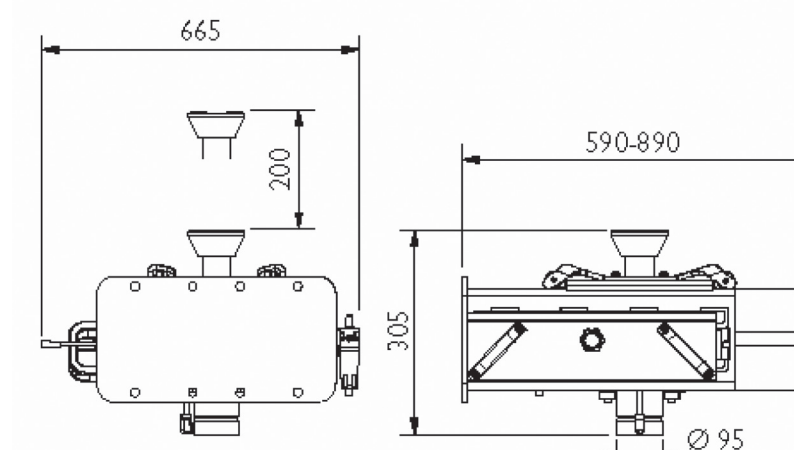

Small traverse



Wide traverse

Mobile 75 H + H WB

Electro-hydraulic mobile lift, 7.5 t capacity per column

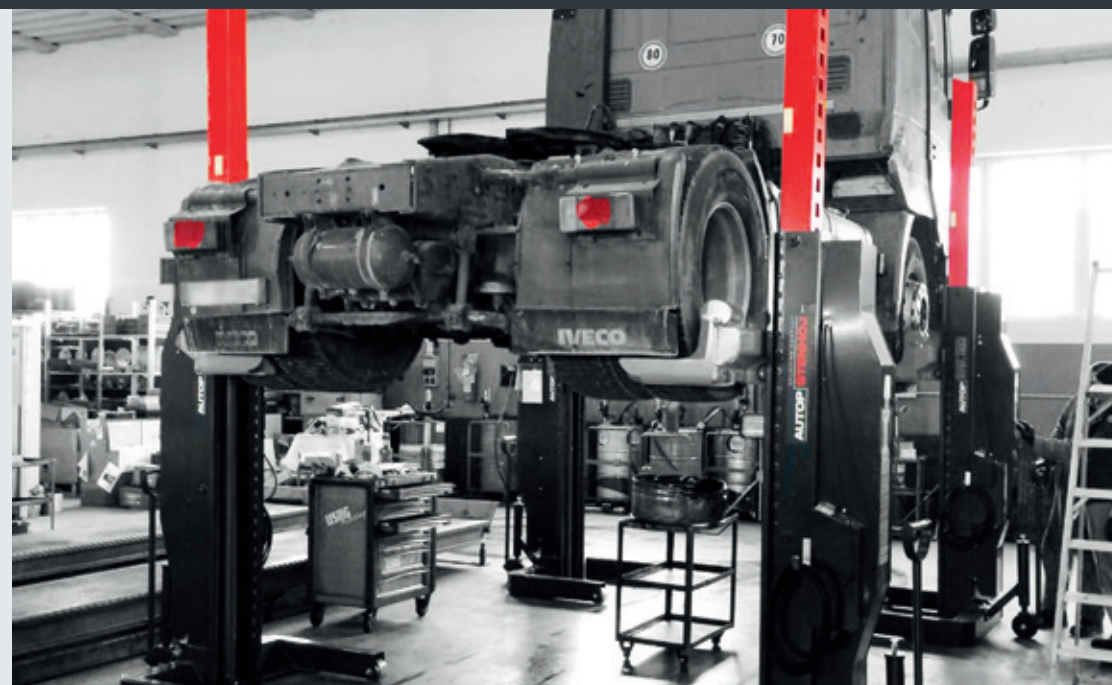

Technical data	
Lifting capacity, up to	7,500 kg
Lifting height	1,800 mm
Stroke length	1,700 mm
Lifting / lowering time	115 / 90 (WB) sec.
Pump unit	1.1 / 2.2 (WB) kW per column
Operation	hydraulic
Voltage	3 x 230 / 400V – 50 Hz – 16 A WB: 115/ 230 V AC, 50/60 Hz, 3 A
Total height	3,700 mm
Min. height	155 mm
Adjustable wheel forks for wheel sizes	min. 550 mm, max. 1,140 mm
Fork length	300 mm

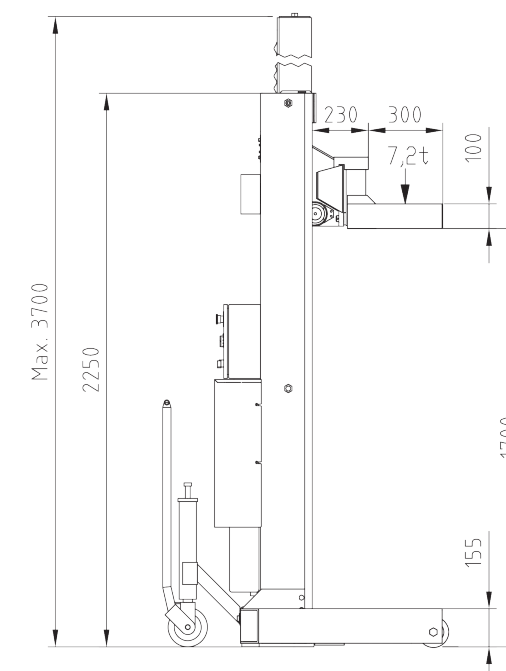
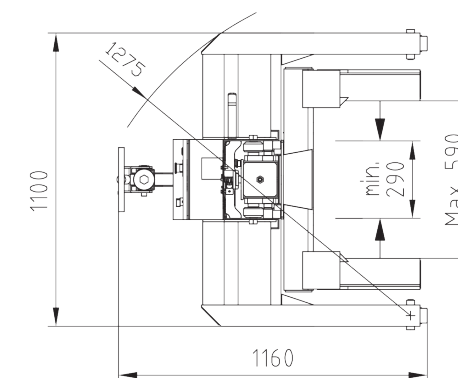

Fork

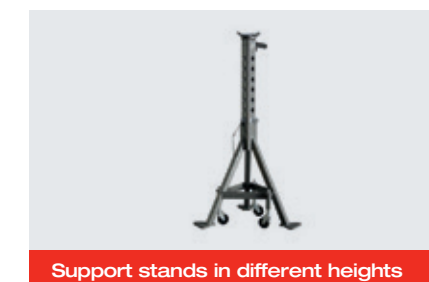

Support stands in different heights

Application

- Repair and maintenance
- Cable version wash/ outdoor installation

Description:

- Protected and sturdy hydraulic cylinder, almost maintenance free
- One Master-column and several Slave-columns, operation modes all or single
- Operation from each column possible
- Maximum work safety through double load protection in every height, meaning mechanical safety ratchets and hydrauliclocking valves
- Cycle control with hydraulic way valves for exact and automatic synchronization ± 2 mm
- Mechanical travelling device on each post, with two wheels in front and rear wheel handle, spring lowers to the ground when loaded and raises the column to make it movable when unloaded
- High ease of use through good movability, easy operation, low setup time and fast lifting time
- Adjustable forks, no adaptors needed
- Circuit cable connection around the vehicle: 10 m cable length each post and 10 m cable length for main power supply

Standard colours:

- Columns: RAL 7016 - grey
- Wheel forks: RAL 3020 - red

Versions:

- Available with different voltages
- Cable version: with 4 or 6 columns, more columns possible with amplifier box
- Wireless version: up to 10 columns

Optional extras:

- Traverse, 15 t
- Support for traverse
- Support stand, 880-1410 mm, 8.2 t
- Support stand, 1350-2130 mm, 8.2 t
- Adjustable wheel
- Remote control for cable version

Special colours available on request!

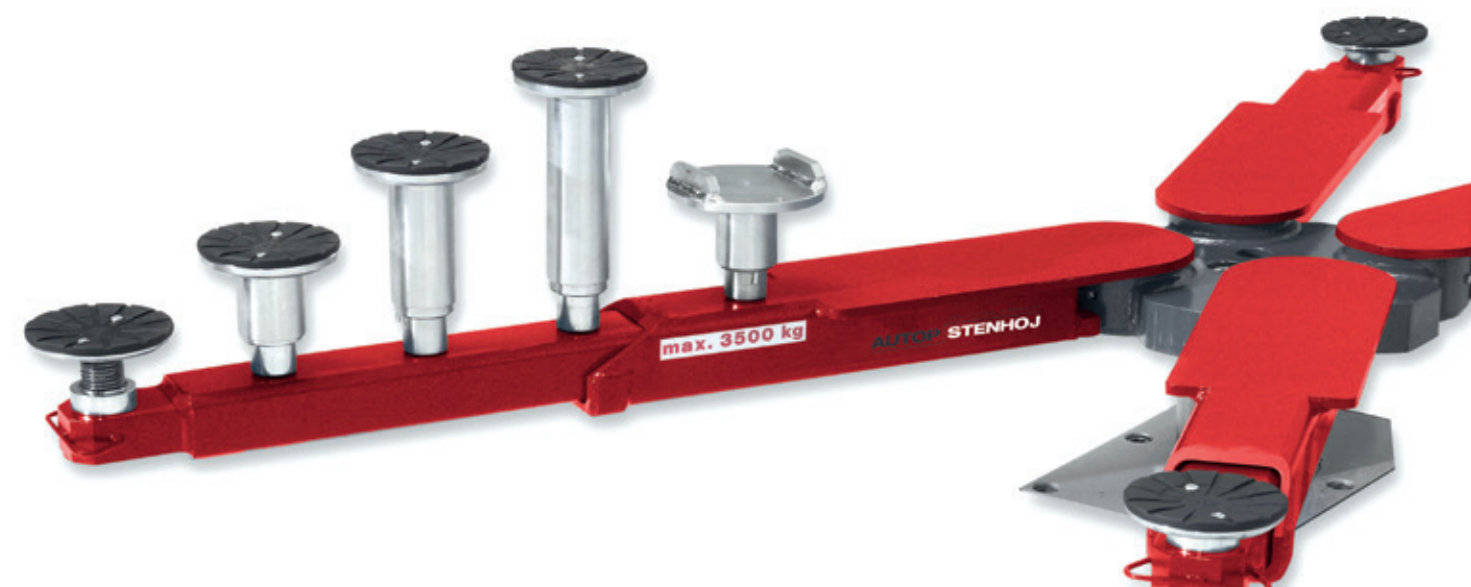

Safe lifting at the highest level.

AUTOPSTENHOJ offers lifts for all kinds of vehicles, and with the extensive range of optional extras such as pads, rubber blocks and wheel supports we offer a unique, safe and professional solution just for your requirement.



AUTOPSTENHOJ pads offer flexibility.

- A wide range of extra pads that enable lifting of vehicles with even very difficult lifting points
- Pads for both inground and surface-mounted lifts
- Fixed as well as adjustable pads in many different heights

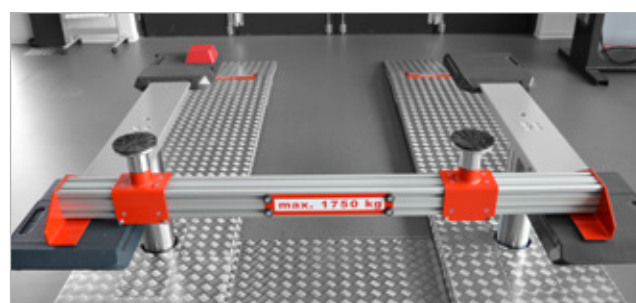

Rubber pads for all vehicles.

- Offers full protection of underbody, when lifting on the recommended lifting points
- Various designs and sizes available



Wheel supports - experience the advantages!

- Easy access to underbody of vehicle
- Ideal as lift can be used for different applications
- Standard distance between supports: 400 mm
- Offroad distance between supports: 500 mm
- Lifting capacity: 875 kg (per wheel support)

Exclusive advantages with exclusive lifts.

The wheel supports are for usage on inground lifts with arms as well as the surface-mounted Maestro 2.50, Maestro 2.55, Maestro 2.65 and Maestro 2.35 F Sport, and should only be used on those lifts.



Power supply at its best!

Is multi-tasking possible? Yes, in fact it is by using power discs or power modules from AUTOPSTENHOJ; as well as our smart power & control column. It makes sense to choose a strong product, as no matter which solution you choose, our products are adapted to local conditions and individual demands to a safe and efficient working area.



Power discs: So many possible connections cover also all future requirements

- Ceiling or wall installation – no obstacles.
- Power and air supply directly to your work bay – no tripping in cables.
- Delivery is inclusive of chain suspension.
- Different adaptors for fitting on e.g. a 2-post lift available.



Power modules: Green light in all respects

- Ceiling installation with protective yoke – safe and always within reach.
- Power and air supply directly to your work bay – no tripping in cables.
- Practical spring suspension for quick access.
- Network connection possible (option).
- We offer a large program of optional extras, e.g. protective yokes, hooks and hand lamp cables.



Power and control columns: Standard sizes offer flexibility

- Different plugs (e.g. Schuko or Cekon) as well as air outlets available.
- The possibility of integrating the control unit of a lift in the column.
- Network connection possible (option).
- Safety quick coupling.
- Practical storage possibilities.

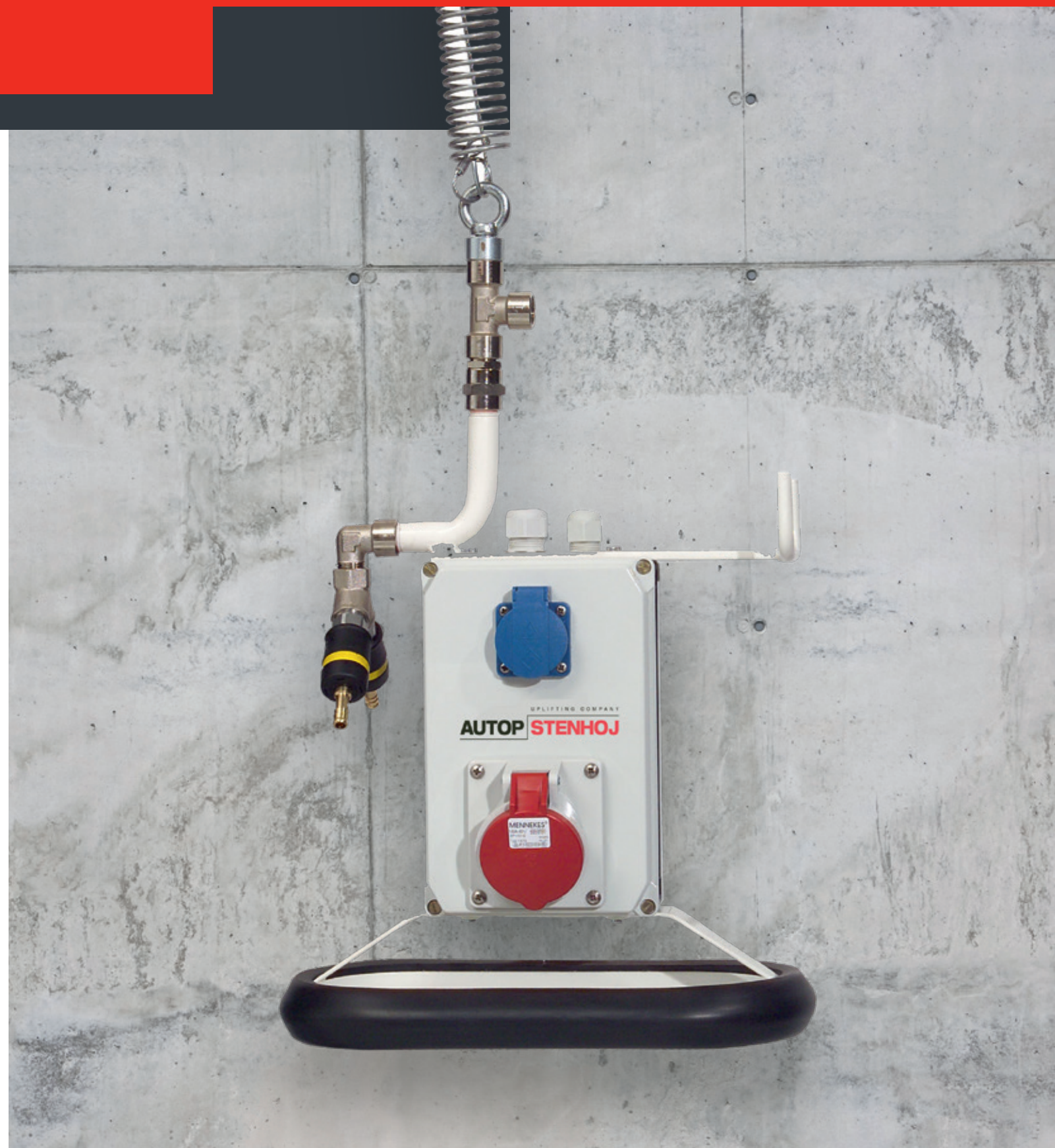

Jet Cleaner RC 82/122

Parts cleaning machines



Technical Data		
	RC 82	RC 122
Usable basket diameter	790 mm	1.190 mm
Usable height	500 mm	500 mm
Loading height	930 mm	830 mm
Max. basket load	300 kg	500 kg
Liquid volume	150 l	370 l
Pump ratio	200 l/min	280 l/min
Pump pressure	3 bar	5 bar
Voltage	230/400 V - 50 Hz - 14 A	230/400 V - 50 Hz - 24 A
Pump motor rating	1.5 kW	4 kW
Heating	6 kW	9 + 6 kW
Basket drive	Jet of water	E-Motor 0.09 kW
Total height	approx. 1,200 mm	approx. 1,300 mm
Total width	approx. 1,300 mm	approx. 1,650 mm
Total depth	approx. 1,300 mm	approx. 1,500 mm
Total weight	approx. 220 kg	approx. 350 kg

Approvals / recommendations

Opel

Description:

Parts cleaning machines made of stainless steel for economical and ecological parts cleaning, degreasing on water basis using spray nozzels.

- Compact and sturdy design
- Made of stainless steel
- Simple handling
- Space saving
- 3D-blast pipe system incl. flat fan nozzles
- Low-water level alarm
- Safety limit switch on cover

Tub cover:

- Track rollers + fixed rollers

Versions:

- RC 82 with 790 mm usable basket diameter
- RC 122 with 1190 mm usable basket diameter

Optional extras:

- Heating timer
- Oil skimmer
- Economy insulation
- Detergents & small parts baskets
- Service counter

Special colours available on request!

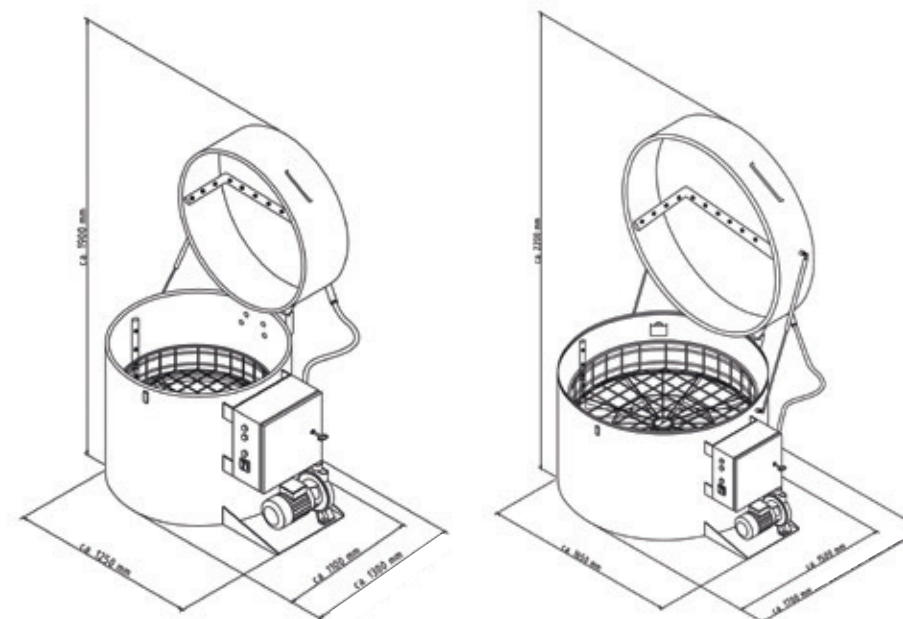

Before cleaning



After cleaning



Архангельск (8182)63-90-72
Астана (7172)727-132
Астрахань (8512)99-46-04
Барнаул (3852)73-04-60
Белгород (4722)40-23-64
Брянск (4832)59-03-52
Владивосток (423)249-28-31
Волгоград (844)278-03-48
Вологда (8172)26-41-59
Воронеж (473)204-51-73
Екатеринбург (343)384-55-89
Иваново (4932)77-34-06

Ижевск (3412)26-03-58
Иркутск (395)279-98-46
Казань (843)206-01-48
Калининград (4012)72-03-81
Калуга (4842)92-23-67
Кемерово (3842)65-04-62
Киров (8332)68-02-04
Краснодар (861)203-40-90
Красноярск (391)204-63-61
Курск (4712)77-13-04
Липецк (4742)52-20-81
Киргизия (996)312-96-26-47

Магнитогорск (3519)55-03-13
Москва (495)268-04-70
Мурманск (8152)59-64-93
Набережные Челны (8552)20-53-41
Нижний Новгород (831)429-08-12
Новокузнецк (3843)20-46-81
Новосибирск (383)227-86-73
Омск (3812)21-46-40
Орел (4862)44-53-42
Оренбург (3532)37-68-04
Пенза (8412)22-31-16
Казахстан (772)734-952-31

Пермь (342)205-81-47
Ростов-на-Дону (863)308-18-15
Рязань (4912)46-61-64
Самара (846)206-03-16
Санкт-Петербург (812)309-46-40
Саратов (845)249-38-78
Севастополь (8692)22-31-93
Симферополь (3652)67-13-56
Смоленск (4812)29-41-54
Сочи (862)225-72-31
Ставрополь (8652)20-65-13

Сургут (3462)77-98-35
Тверь (4822)63-31-35
Томск (3822)98-41-53
Тула (4872)74-02-29
Тюмень (3452)66-21-18
Ульяновск (8422)24-23-59
Уфа (347)229-48-12
Хабаровск (4212)92-98-04
Челябинск (351)202-03-61
Череповец (8202)49-02-64
Ярославль (4852)69-52-93

<https://autop.nt-rt.ru> || aft@nt-rt.ru