

Архангельск (8182)63-90-72
 Астана (7172)727-132
 Астрахань (8512)99-46-04
 Барнаул (3852)73-04-60
 Белгород (4722)40-23-64
 Брянск (4832)59-03-52
 Владивосток (423)249-28-31
 Волгоград (844)278-03-48
 Вологда (8172)26-41-59
 Воронеж (473)204-51-73
 Екатеринбург (343)384-55-89
 Иваново (4932)77-34-06

Ижевск (3412)26-03-58
 Иркутск (395)279-98-46
 Казань (843)206-01-48
 Калининград (4012)72-03-81
 Калуга (4842)92-23-67
 Кемерово (3842)65-04-62
 Киров (8332)68-02-04
 Краснодар (861)203-40-90
 Красноярск (391)204-63-61
 Курск (4712)77-13-04
 Липецк (4742)52-20-81
 Киргизия (996)312-96-26-47

Магнитогорск (3519)55-03-13
 Москва (495)268-04-70
 Мурманск (8152)59-64-93
 Набережные Челны (8552)20-53-41
 Нижний Новгород (831)429-08-12
 Новокузнецк (3843)20-46-81
 Новосибирск (383)227-86-73
 Омск (3812)21-46-40
 Орел (4862)44-53-42
 Оренбург (3532)37-68-04
 Пенза (8412)22-31-16
 Казахстан (772)734-952-31

Пермь (342)205-81-47
 Ростов-на-Дону (863)308-18-15
 Рязань (4912)46-61-64
 Самара (846)206-03-16
 Санкт-Петербург (812)309-46-40
 Саратов (845)249-38-78
 Севастополь (8692)22-31-93
 Симферополь (3652)67-13-56
 Смоленск (4812)29-41-54
 Сочи (862)225-72-31
 Ставрополь (8652)20-65-13

Сургут (3462)77-98-35
 Тверь (4822)63-31-35
 Томск (3822)98-41-53
 Тула (4872)74-02-29
 Тюмень (3452)66-21-18
 Ульяновск (8422)24-23-59
 Уфа (347)229-48-12
 Хабаровск (4212)92-98-04
 Челябинск (351)202-03-61
 Череповец (8202)49-02-64
 Ярославль (4852)69-52-93

<https://autop.nt-rt.ru> || aft@nt-rt.ru

Maestro 32 M

Electro-mechanical 2-post lift with 3.2 t capacity

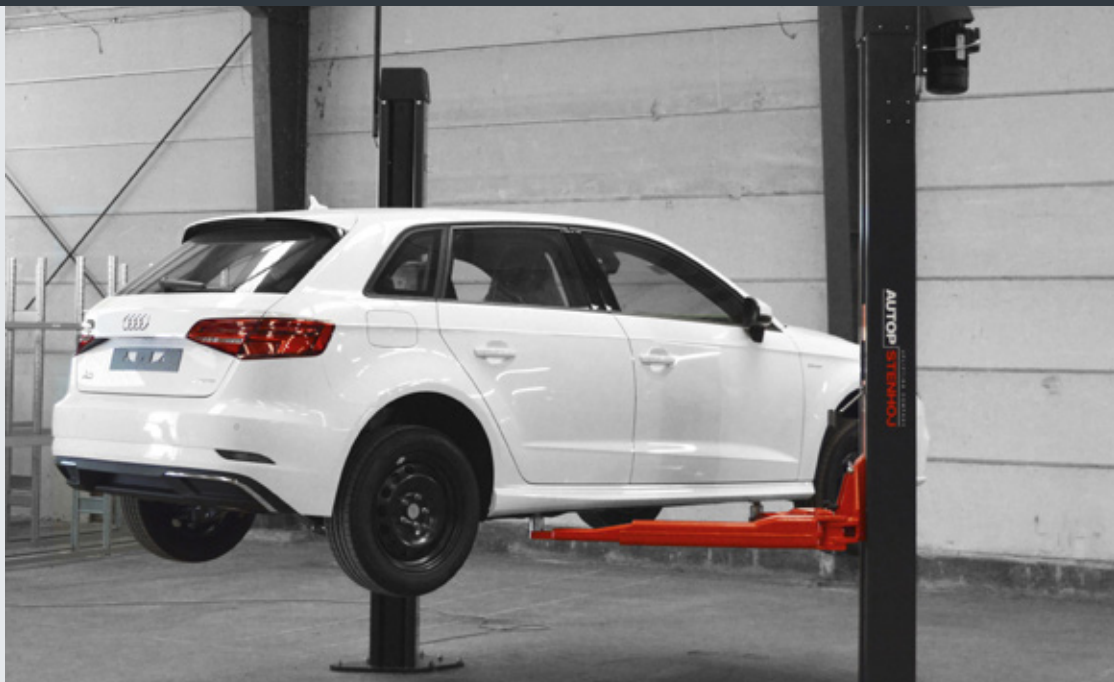

Application

- Repair and maintenance

Approvals / recommendations

- Volvo

Description:

Posts:

- Asymmetric post installation, vehicles can be positioned in rear area of work bay, for better door-opening angle
- Very stable bent posts
- Without base frame, therefore free drive-in situation
- Two strong electric motors
- Cold-rolled spindles for high durability
- Nylon nut sets for high durability
- Long carriage with optimized mounting of 8 sliding blocks for low friction
- Carriage with threaded holes for easy adoption of diverse superstructures
- Door-stop mounted on carriage
- Obstruction system for stopping the lift when it hits an obstacle
- Pushbutton control unit with alarm signal
- Programmable limit switch for top stop and CE-stop
- Electronic synchronization through comparison of pulses measured on the pulleys

Arms:

- Universal lifting area from small passenger car up to BMW series 7 long G12
- Possibility of parallel parking of arms for easier and faster positioning of vehicles
- Arms can be opened more than 180° for better drive-in situation (+45°) for lifts installed in 90° angle to the drive lane
- Low minimum height

Standard colours:

- Carriage and arms: RAL 3020 – red
- Posts: RAL 7016 – grey

Versions:

- Available with different voltages
- F = flex pad
- DT/DT = double telescopic short arms / double telescopic short arms

Optional extras:

- Available with different portal heights, alternatively inground kit
- Set of expansion bolts
- LED-lighting set, flexible with spiral cable, fastening through magnets on posts or vehicle
- Energy set with compressed air and socket-outlet
- Extra control unit for second post
- Large program of extra pads, depending on type of vehicle

Special colours available on request!

Technical data	
Lifting capacity	3,200 kg
Lifting height	1,900 mm
Working height	2,000 - 2,040 mm
Lifting / lowering time	approx. 35 sec.
Motor	2 x 2.8 kW
Voltage	3 x 230 / 400V – 50 Hz – 20 A

Arm superstructure	
Lifting pad included in the delivery	F: 11027: 100 – 140 mm
Height of plug-in in superstructure	F Standard: 53 mm
Min. height	88 mm (78 mm with extra lifting pad 29265)
Drive-through width	2,205 mm
Width between posts	2,565 mm
Total width - outer edges base plates	3,250 mm
Total height post	3,100 mm
Total height incl. portal	4,060 - 4,420 mm
Arm length front, min. - max.	F DT: 555 - 1,100 mm
Arm length rear, min. - max.	F DT: 555 - 1,100 mm

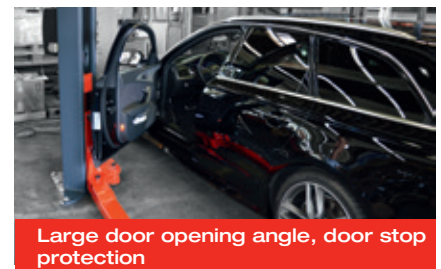
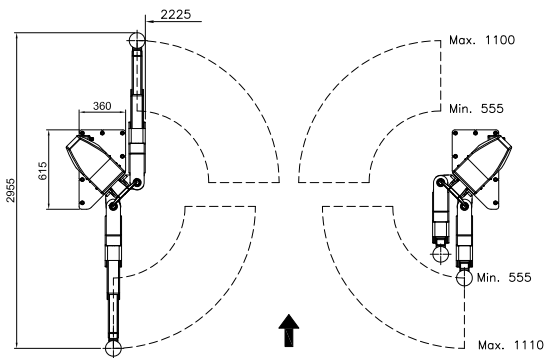
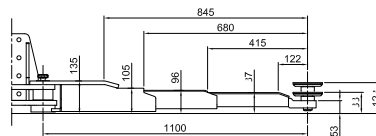
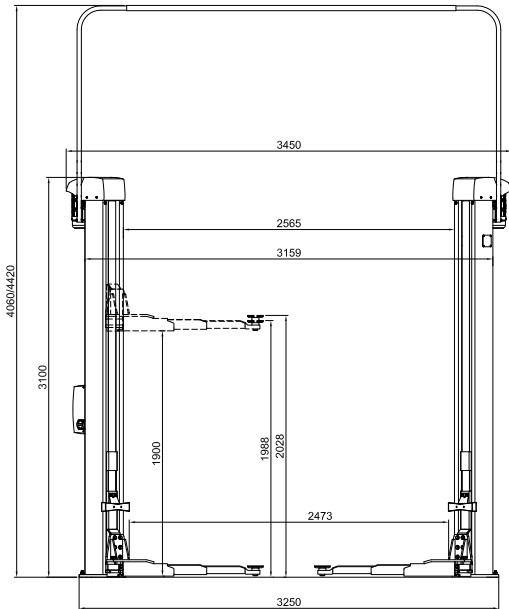

Архангельск (8182)63-90-72
 Астана (7172)727-132
 Астрахань (8512)99-46-04
 Барнаул (3852)73-04-60
 Белгород (4722)40-23-64
 Брянск (4832)59-03-52
 Владивосток (423)249-28-31
 Волгоград (844)278-03-48
 Вологда (8172)26-41-59
 Воронеж (473)204-51-73
 Екатеринбург (343)384-55-89
 Иваново (4932)77-34-06

Ижевск (3412)26-03-58
 Иркутск (395)279-98-46
 Казань (843)206-01-48
 Калининград (4012)72-03-81
 Калуга (4842)92-23-67
 Кемерово (3842)65-04-62
 Киров (8332)68-02-04
 Краснодар (861)203-40-90
 Красноярск (391)204-63-61
 Курск (4712)77-13-04
 Липецк (4742)52-20-81
 Киргизия (996)312-96-26-47

Магнитогорск (3519)55-03-13
 Москва (495)268-04-70
 Мурманск (8152)59-64-93
 Набережные Челны (8552)20-53-41
 Нижний Новгород (831)429-08-12
 Новокузнецк (3843)227-86-73
 Новосибирск (383)227-86-73
 Омск (3812)21-46-40
 Орел (4862)44-53-42
 Оренбург (3532)37-68-04
 Пенза (8412)22-31-16
 Казахстан (772)734-952-31

Пермь (342)205-81-47
 Ростов-на-Дону (863)308-18-15
 Рязань (4912)46-61-64
 Самара (846)206-03-16
 Санкт-Петербург (812)309-46-40
 Саратов (845)249-38-78
 Севастополь (8692)22-31-93
 Симферополь (3652)67-13-56
 Смоленск (4812)29-41-54
 Сочи (862)225-72-31
 Ставрополь (8652)20-65-13

Сургут (3462)77-98-35
 Тверь (4822)63-31-35
 Томск (3822)98-41-53
 Тула (4872)74-02-29
 Тюмень (3452)66-21-18
 Ульяновск (8422)24-23-59
 Уфа (347)229-48-12
 Хабаровск (4212)92-98-04
 Челябинск (351)202-03-61
 Череповец (8202)49-02-64
 Ярославль (4852)69-52-93